

## Typ AE1+1H, AE2+2H, AE4H

### Pompy monośrubowe

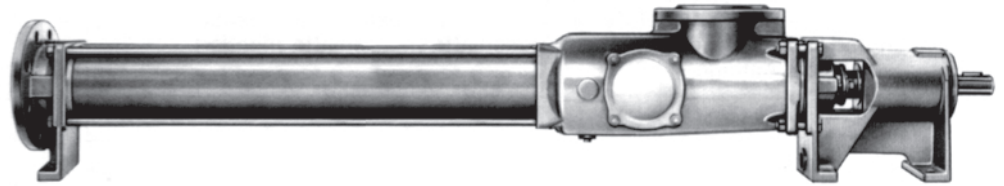

#### Dane techniczne

Wydajność	Q	l/min	do	2900
Temperatura medium	t	°C <sup>1)</sup>	do	150
Ciśnienie tłoczenia pompy	$\Delta p$	bar	do	24
Końcowe ciśnienie pompy	$p_d$	bar <sup>3)</sup>	do	25
Osiągane podciśnienie	$p_s$	bar <sup>2)</sup>	do	0,95
Lepkość	$\eta$	mPa s <sup>2)</sup>	do	270000
Dopuszcz. udział cząstek stałych		% obj. <sup>2)</sup>	do	60

<sup>1)</sup> Zależnie od tłoczonego medium i zastosowanego elastomeru

<sup>2)</sup> Zależnie od wielkości pompy, liczby obrotów i tłoczonego medium

<sup>3)</sup> Zależnie od wejściowego ciśnienia i uszczelnienia wału

#### Dopuszczalne wielkości ziaren i długości włókien:

Wielkość pompy	12	25	50	100	200	380
max. wielkość ziaren mm	2	2,5	3	3,8	5	6,8
max. długość włókien mm	35	42	42	48	60	79

Wielkość pompy	750	1450	2700
max. wielkość ziaren mm	9,5	14	20
max. długość włókien mm	98	130	210

Wyższy udział zawartości części stałych i zwiększanie grubości ziaren powoduje konieczność redukcji obrotów na niższe.

#### Charakterystyki

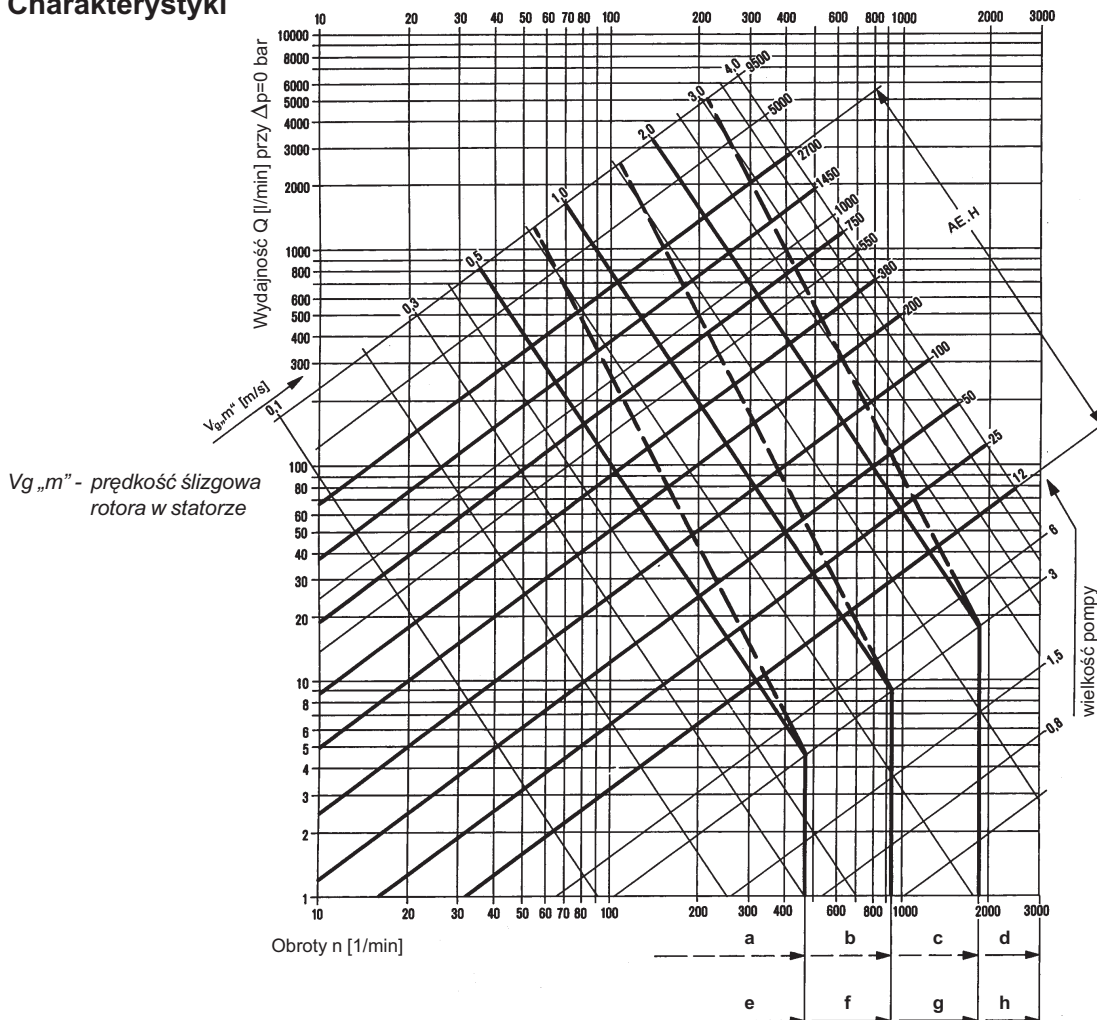

# Typ AE1+1H, AE2+2H, AE4H

Wymiary pomp, pozycje króćców, ciężary

## Typ AE1+1H, AE2+2H

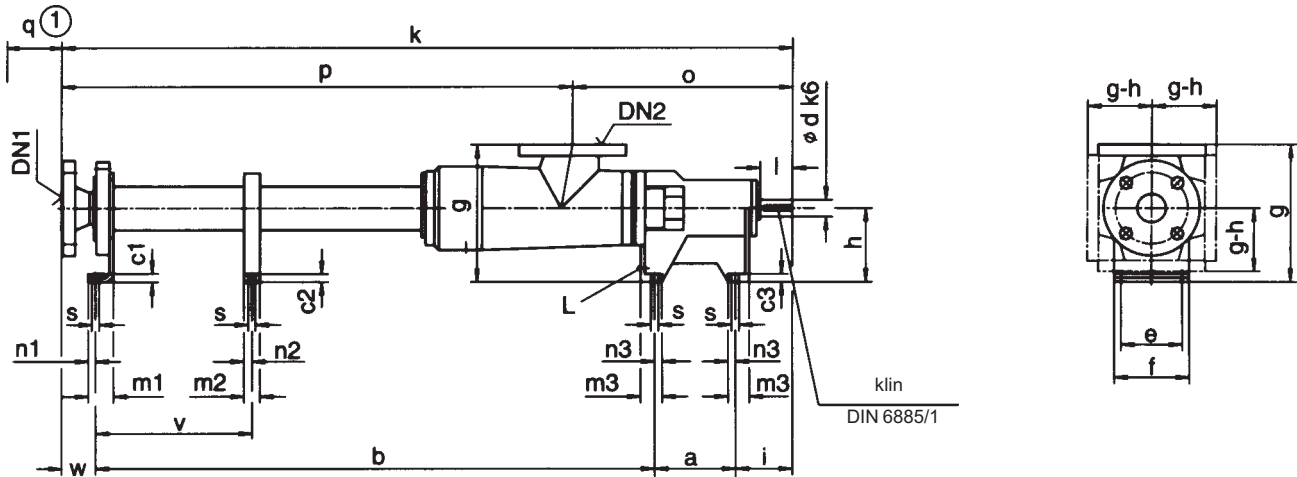

## Typ AE2H, AE4H

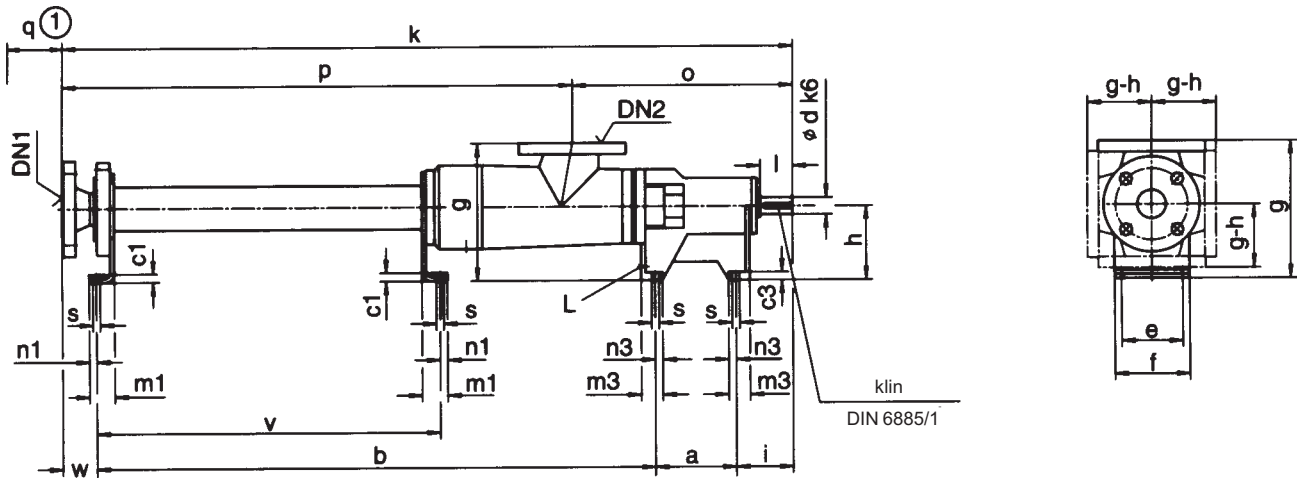

Możliwe ustawienia króćców

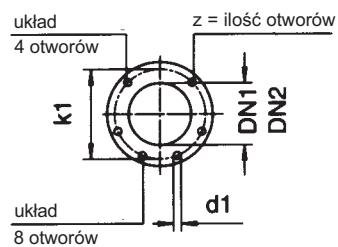
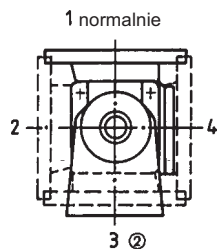

(2) niedostępne dla pomp AE4H 12

## Typ AE1+1H, AE2+2H, AE4H

wymiary w mm (kolnierze ANSI w calach)

Wielkość	Wymiary pompy																				Ciężar (kg)		
	a	b	c <sub>1</sub>	c <sub>2</sub>	c <sub>3</sub>	d	e	f	h	i	l	m <sub>1</sub>	m <sub>2</sub>	m <sub>3</sub>	n <sub>1</sub>	n <sub>2</sub>	n <sub>3</sub>	o	q <sup>1)</sup>	s		L	v
AE4H 12 - ID	114	668	8	-	10	18	75	95	90	65	30	42	-	30	11	-	11	273	360	9	Rp 3/8	-	20
AE4H 25 - ID	122	814	8	-	10	22	85	105	100	79	40	42	-	30	11	-	11	309	465	9	Rp 3/8	-	30
AE4H 50 - ID	140	1032	13	-	13	28	100	125	125	95	50	48	-	38	13	-	13	371	605	12	Rp 3/8	-	52
AE2H 100 - ID	151	859	16	-	15	32	114	140	140	106	60	48	-	40	14	-	14	411	360	16	Rp 3/4	-	62
AE2+2H 100 - ID	151	1277	16	15	15	32	114	140	140	106	60	48	35	40	14	17,5	14	411	360	16	Rp 3/4	431	86
AE4H 100 - ID	151	1259	16	-	15	32	114	140	140	106	60	48	-	40	14	-	14	411	760	16	Rp 3/4	856	80
AE2H 200 - ID	171	1047,5	16	-	16	42	132	168	160	118	65	50	-	50	19	-	19	479,5	465	18	Rp 3/4	-	93
AE2+2H 200 - ID	171	1573,5	16	16	16	42	132	168	160	118	65	50	40	50	19	20	19	479,5	470	18	Rp 3/4	535	133
AE4H 200 - ID	171	1551,5	16	-	16	42	132	168	160	118	65	50	-	50	19	-	19	479,5	950	18	Rp 3/4	1058	123
AE2H 380 - ID	190	1268,5	16	-	16	48	164	200	180	129,5	75	50	-	50	19	-	19	532	560	18	Rp 3/4	-	155
AE2+2H 380 - ID	190	1906,5	16	16	16	48	164	200	180	129,5	75	50	45	50	19	22,5	19	532	570	18	Rp 3/4	644,5	226
AE4H 380 - ID	190	1906,5	16	-	16	48	164	200	180	129,5	75	50	-	50	19	-	19	532	1210	18	Rp 3/4	1303	210
AE2H 750 - ID	220	1618	20	-	21	60	200	245	225	158	90	70	-	63	23	-	23	644	750	22	Rp 1	-	300
AE2+2H 750 - ID	220	2448	20	21	21	60	200	245	225	158	90	70	45	63	23	22,5	23	644	980	22	Rp 1	850,5	414
AE4H 750 - ID	220	2448	20	-	21	60	200	245	225	158	90	70	-	63	23	-	23	644	1600	22	Rp 1	1721	390
AE2H 1450 - ID	266	2030	20	-	24	75	245	290	250	182	110	70	-	65	23	-	23	769	950	22	Rp 1	1103	498
AE2+2H 1450 - ID	266	3076	20	24	24	75	245	290	250	182	110	70	50	65	23	25	23	769	950	22	Rp 1	1065	690
AE4H 1450 - ID	266	3076	20	-	24	75	245	290	250	182	110	70	-	65	23	-	23	769	1990	22	Rp 1	2149	655
AE1+1H 2700 - ID	320	2508	28	29	29	95	290	350	280	215	130	80	55	80	30	27,5	30	922	980	27	Rp 1	677	780
AE2+2H 2700 - ID	320	3824	28	29	29	95	290	350	280	215	130	80	55	80	30	27,5	30	922	1220	27	Rp 1	1335	1030

Wielkość	Wymiary przyłączy dla króćców tłocznych														
	Kolnierz DIN 2501, PN 25 <sup>3)</sup>								Kolnierz ANSI B16.5 RF, Class 300 <sup>4)</sup>						
	DN <sub>1</sub>	d <sub>1</sub>	<sup>5)</sup> k	<sup>5)</sup> k <sub>1</sub>	<sup>5)</sup> p	<sup>5)</sup> w	z	DN <sub>1</sub>	d <sub>1</sub>	<sup>5)</sup> k	<sup>5)</sup> k <sub>1</sub>	<sup>5)</sup> p	<sup>5)</sup> w	z	
AE4H 12 - ID	32	18	886	100	613	39	4	1 1/4	19	908	98,4	635	61	4	
AE4H 25 - ID	40	18	1062	110	753	47	4	1 1/2	22,2	1084	114,3	775	69	4	
AE4H 50 - ID	50	18	1315	125	944	48	4	2	19	1336,5	127	965,5	69,5	8	
AE2H 100 - ID	65	18	1171	145	760	55	8	2 1/2	22,2	1195,2	149,5	784,2	79,2	8	
AE2+2H 100 - ID	65	18	1589	145	1178	55	8	2 1/2	22,2	1613,2	149,2	1202,2	79,2	8	
AE4H 100 - ID	65	18	1571	145	1160	55	8	2 1/2	22,2	1595,2	149,2	1184,2	79,2	8	
AE2H 200 - ID	80	18	1398,5	160	919	62	8	3	22,2	1418,5	168,3	939	82	8	
AE2+2H 200 - ID	80	18	1924,5	160	1445	62	8	3	22,2	1944,5	168,3	1465	82	8	
AE4H 200 - ID	80	18	1902,5	160	1423	62	8	3	22,2	1922,5	168,3	1443	82	8	
AE2H 380 - ID	100	22	1662	190	1130	74	8	4	22,2	1681	200	1149	93	8	
AE2+2H 380 - ID	100	22	2300	190	1768	74	8	4	22,2	2319	200	1787	93	8	
AE4H 380 - ID	100	22	2300	190	1768	74	8	4	22,2	2319	200	1787	93	8	
AE2H 750 - ID	125	26	2069	220	1425	73	8	5	22,2	2099,5	234,9	1455,5	103,5	8	
AE2+2H 750 - ID	125	26	2899	220	2255	73	8	5	22,2	2929,5	234,9	2285,5	103,5	8	
AE4H 750 - ID	125	26	2899	220	2255	73	8	5	22,2	2929,5	234,9	2285,5	103,5	8	
AE2H 1450 - ID	150	26	2555	250	1786	77	8	6	22,2	2577	269,9	1808	99	12	
AE2+2H 1450 - ID	150	26	3601	250	2832	77	8	6	22,2	3623	269,9	2854	99	12	
AE4H 1450 - ID	150	26	3601	250	2832	77	8	6	22,2	3623	269,9	2854	99	12	
AE1+1H 2700 - ID	200	26	3129	310	2207	86	12	8	25,4	3160	330,2	2238	117	12	
AE2+2H 2700 - ID	200	26	4445	310	3523	86	12	8	25,4	4476	330,2	3554	117	12	

## Typ AE1+1H, AE2+2H, AE4H

Wielkość	Wymiary przyłączy dla króćców ssących														
	Kołnierz DIN 2501, PN 16 <sup>6)</sup>						Kołnierz ANSI B16.1, Class 125 <sup>4)</sup>					Kołnierz ANSI B16.5 RF, Class 150 <sup>4)</sup>			
	DN <sub>2</sub>	d <sub>1</sub>	<sup>5)</sup> g	k <sub>1</sub>	z	DN <sub>2</sub>	d <sub>1</sub>	<sup>5)</sup> g	k <sub>1</sub>	z	DN <sub>2</sub>	d <sub>1</sub>	<sup>5)</sup> g	k <sub>1</sub>	z
AE4H 12 - ID	40	18	175	110	4	1 1/2	15,9	172	98,4	4	1 1/2	15,9	175	98,4	4
AE4H 25 - ID	50	18	190	125	4	2	19	186	120,6	4	2	19	190	120,6	4
AE4H 50 - ID	65	18	230	145	4	2 1/2	19	229	139,7	4	2 1/2	19	234	139,7	4
AE2H 100 - ID	80	18	260	160	8	3	19	258	152,4	4	3	19	263	152,4	4
AE2+2H 100 - ID	80	18	260	160	8	3	19	258	152,4	4	3	19	263	152,4	4
AE4H 100 - ID	80	18	260	160	8	3	19	258	152,4	4	3	19	263	152,4	4
AE2H 200 - ID	100	18	300	180	8	4	19	302	190,5	8	4	19	302	190,5	8
AE2+2H 200 - ID	100	18	300	180	8	4	19	302	190,5	8	4	19	302	190,5	8
AE4H 200 - ID	100	18	300	180	8	4	19	302	190,5	8	4	19	302	190,5	8
AE2H 380 - ID	125	18	350	210	8	5	22,2	350	215,9	8	5	22,2	350	215,9	8
AE2+2H 380 - ID	125	18	350	210	8	5	22,2	350	215,9	8	5	22,2	350	215,9	8
AE4H 380 - ID	125	18	350	210	8	5	22,2	350	215,9	8	5	22,2	350	215,9	8
AE2H 750 - ID	150	22	425	240	8	6	22,2	425	241,3	8	6	22,2	425	241,3	8
AE2+2H 750 - ID	150	22	425	240	8	6	22,2	425	241,3	8	6	22,2	425	241,3	8
AE4H 750 - ID	150	22	425	240	8	6	22,2	425	241,3	8	6	22,2	425	241,3	8
AE2H 1450 - ID	200	22	485	295	12	8	22,2	485	298,4	8	8	22,2	485	298,4	8
AE2+2H 1450 - ID	200	22	485	295	12	8	22,2	485	298,4	8	8	22,2	485	298,4	8
AE4H 1450 - ID	200	22	485	295	12	8	22,2	485	298,4	8	8	22,2	485	298,4	8
AE1+1H 2700 - ID	250	26	550	355	12	10	25,4	550	361,9	12	10	25,4	550	361,9	12
AE2+2H 2700 - ID	250	26	550	355	12	10	25,4	550	361,9	12	10	25,4	550	361,9	12

<sup>1)</sup> wymiar do demontażu statora

<sup>3)</sup> powierzchnia uszczelniająca wg DIN 2526 Forma C

<sup>4)</sup> powierzchnia uszczelniająca: stock finish

<sup>5)</sup> przy pompie gumowanej + 3 mm

<sup>6)</sup> do DN 100 powierzchnia uszczelniająca wg DIN 2526 Forma C  
od DN 125 powierzchnia uszczelniająca wg DIN 2526 Forma A