

Control valves
RV 501



Kv coefficient calculation

Calculation itself is carried out with respect to conditions of regulating circuit and operating medium according to equations mentioned below. Control valve must be designed to be able to regulate maximal flow quantity at given operating conditions. At the same time it is necessary to check whether minimal flow quantity can be even regulated or not.

Because of eventual minus tolerance 10% of Kv_{100} against Kvs and requirement for possible regulation within range of maximal flow (decrement and increase of flow), producer recommends to select Kvs value higher than maximal operating Kv value:

$$Kvs = 1.2 \div 1.3 Kv$$

It is necessary to take into account to which extent Q_{max} involve "precautionary additions" that could result in valve oversizing.

Relations of Kv calculation

		Pressure drop $p_2 > p_1/2$ $\Delta p < p_1/2$	Pressure drop $\Delta p \geq p_1/2$ $p_2 \leq p_1/2$
Kv =	Liquid	$\frac{Q}{100} \sqrt{\frac{\rho_1}{\Delta p}}$	
	Gas	$\frac{Q_n}{5141} \sqrt{\frac{\rho_n \cdot T_1}{\Delta p \cdot p_2}}$	$\frac{2 \cdot Q_n}{5141 \cdot p_1} \sqrt{\rho_n \cdot T_1}$
	Superh. steam	$\frac{Q_m}{100} \sqrt{\frac{v_2}{\Delta p}}$	$\frac{Q_m}{100} \sqrt{\frac{2v}{p_1}}$
	Sat. steam	$\frac{Q_m}{100} \sqrt{\frac{v_2 \cdot x}{\Delta p}}$	$\frac{Q_m}{100} \sqrt{\frac{2v \cdot x}{p_1}}$

Above critical flow of vapours and gases

When pressure ratio is above critical ($p_2/p_1 < 0.54$), speed of flow reaches acoustic velocity at the narrowest section. This event can cause higher level of noisiness and then it is convenient to use a throttling system ensuring low noisiness (multi-step pressure reduction, damping orifice plate at outlet).

Cavitation

Cavitation is a phenomenon when there are steam bubbles creating and vanishing in shocks - generally at the narrowest section of flowing due to local pressure drop. This event

Dimensions and units

Marking	Unit	Name of dimension
Kv	m ³ /hour	Flow coefficient under conditions of units of flow
Kv_{100}	m ³ /hour	Flow coefficient at nominal stroke
Kvs	m ³ /hour	Valve nominal flow coefficient
Q	m ³ /hour	Flow rate in operating conditions (T_1, p_1)
Q_n	Nm ³ /hour	Flow rate in normal conditions (0 °C, 0.101 MPa)
Q_m	kg/hour	Flow rate in operating conditions (T_1, p_1)
p_1	MPa	Upstream absolute pressure
p_2	MPa	Downstream absolute pressure
p_s	MPa	Absolute pressure of saturated steam at given temperature (T_1)
Δp	MPa	Valve differential pressure ($\Delta p = p_1 - p_2$)
ρ_1	kg/m ³	Process medium density in operating conditions (T_1, p_1)
ρ_n	kg/Nm ³	Gas density in normal conditions (0 °C, 0.101 MPa)
v_2	m ³ /kg	Specific volume of steam when temperature T_1 and pressure p_2
v	m ³ /kg	Specific volume of steam when temperature T_1 and pressure $p_1/2$
T_1	K	Absolute temperature at valve inlet ($T_1 = 273 + t_1$)
x	1	Proportionate weight volume of saturated steam in wet steam

expressively cuts down service life of inner parts and can result in creation of unpleasant vibrations and noisiness. In control valves it can happen on condition that

$$(p_1 - p_2) \geq 0.6 (p_1 - p_s)$$

Valve differential pressure should be set the way so that neither any undesired pressure drop causing cavitation can occur, nor liquid-steam(wet steam) mixture can create. Otherwise it must be taken into account when calculating Kv value. If the creation of cavitation still threatens, it is necessary to use a multi-step pressure reduction.

Valve flow characteristics

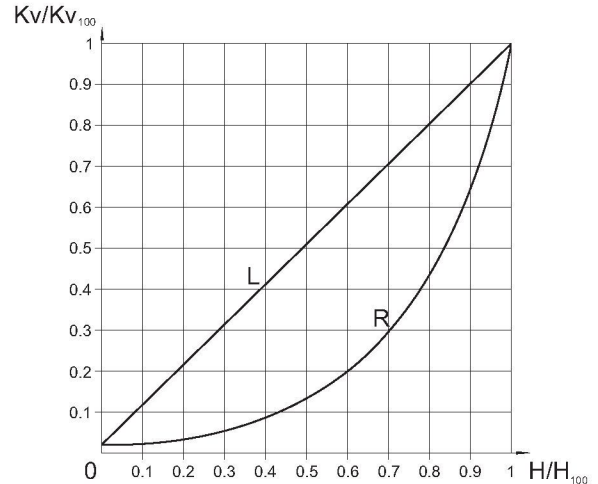

L - linear characteristic

$$Kv/Kv_{100} = 0.0183 + 0.9817 \cdot (H/H_{100})$$

R - equal-percentage characteristic (4-percentage)

$$Kv/Kv_{100} = 0.0183 \cdot E^{(4 \cdot H/H_{100})}$$

Rangeability

Rangeability is the ratio of the biggest value of flow coefficient to the smallest value. In fact it is the ratio (under the same conditions) of highest regulated flow rate value to its lowest value.

The lowest or minimal regulated flow rate is always higher than 0.

Diagram for the valve Kvs value specification according to the required flow rate of water Q and the valve differential pressure Δp

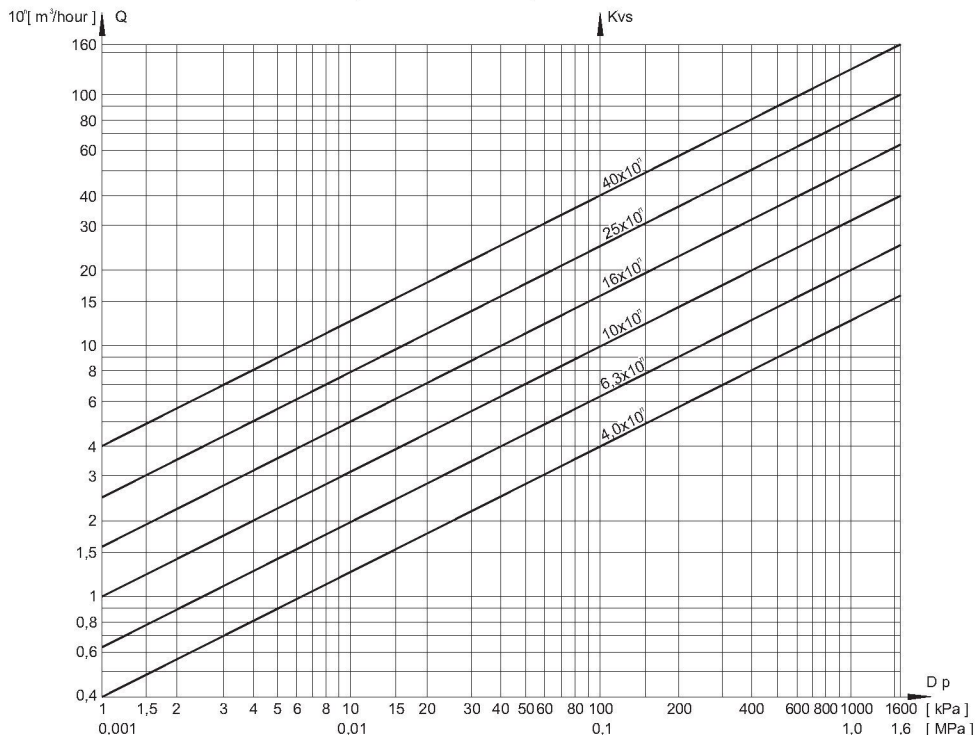

The diagram serves to specify the valve Kvs value regarding to the required flow rate of water at a given differential pressure. It can be also used for finding out the differential pressure value of the existing valve in behaviour with the flow rate. The diagram applies to water with the density of 1000 kg/m^3 .

For the value $Q = q \cdot 10^n$, it is necessary to calculate with $Kvs = k \cdot 10^n$. Example: water flow rate of $16 \cdot 10^{-1} = 1,6 \text{ m}^3/\text{hour}$ corresponds to $Kv = 2,5 = 25 \cdot 10$ when differential pressure 40 kPa .

Application of multi-step pressure reduction

When the valves are designed for operation in above-critical differential pressure ($p_2/p_1 < 0,54$ when throttling steam and gases), or when diff. pressure value is higher than the recom-

mended service diff. pressure, it is effectual to use a throttling system in two or three steps to prevent the cavitation from creating and to ensure both a long service life of the valve inner parts and low noisiness when operating.

One-step pressure reduction

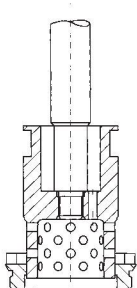

Two-step pressure reduction

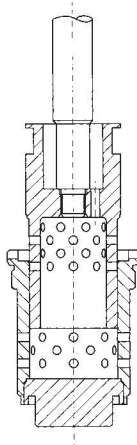

Three-step pressure reduction

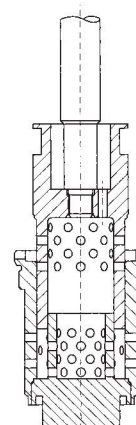



Control valves DN 15 to 150 , PN 16 to 160

Description

The valves series RV 501 are single-seated control valves of a unit construction designed to fit in all demands of an appliance the valve is designed for. The pressure-balanced, multi-step throttling system is always designed with regard to the resistance to creation and effects of cavitation and noisiness.

The valves can be delivered with weld ends or flanges having faces acc. to the customer's requirements and demands.

The valves are actuated with linear actuators. The connection is designed for using both domestic and foreign actuators of the following producers: ZPA Nová Paka, ZPA Pečky, Regada Prešov, Auma, Schiebel and Foxboro.

Process media

The valves are especially designed for the flow and pressure control of the process medium without impurities, however they can be used for gases and vapours when inlet and outlet flow velocities are kept within the permissible range. The common process media are for example water, steam and other media with no special demands on the used type of material of the valve. The producer recommends to pipe a strainer into pipeline in front of the valve when impurities are present. Impurities can affect the quality and reliability of regulation and can cause a reduction of the valve service life. The valve application for any other media should be consulted with the producer because of the type of material that is in contact with the process medium.

Application

The sphere of application of these valves continues in the sphere of application for the valves series RV 210 to RV 235. They are especially designed for industry applications such as heating plants, power plants or regulation of technology processes. The max. permissible operating pressure values correspond to EN 12 516-1 see page 22 of this catalogue.

Installation

The valves must be piped the way so that the process medium flow will coincide with the arrows indicated on the valve body. They can be installed in horizontal, vertical or inclined pipeline in any position except the position when the actuator is under the valve body.

Recommended differential pressures

In regard to the pressure balancing of the plug and to linear forces of usable actuators, the valves' application in high differential pressures is not limited by the forces caused by process medium pressure but by the type of used throttling system. A recommended max. differential pressure for one step of a multi-step pressure reduction is 4.0 MPa when perforated plug and perforated cage are used and 2.0 MPa when a parabolic plug is used. It is recommended to consult the producer and discuss the concrete cases with regard to pressure ratio and service parameters of other equipment.

Technical data

Series	RV 501	
Type of valve	Control valve, single-seated, straight-through, with pressure-balanced plug	
Nominal size range	DN 15 to 150	
Nominal pressure	PN 16 to 160	
Body material	Carbon steel 1.0619 (GP 240 GH)	Alloy steel 1.7357(G17CrMo5-5)
Material of weld ends	1.0425 (P 265 GH)	1.7335 (13CrMo4-5)
Seat material: DN 15 - 150	17 021.6 (1.4006)	
Plug material: DN 15 - 150	17 123.6 (1.4078)	
Operating temp. range	-20 to 400 °C	-20 to 550 °C
Connection flanges	For PN 16 to 100 acc. to ČSN EN 1092-1 (2/2003), for PN 160 acc. to DIN 2548 (4/1969)	
Type of flanges	Type B1 acc. to ČSN EN 1092-1 (2/2003) - raised flange	
	Type F acc. to ČSN EN 1092-1 (2/2003) - female flange	
	Type B2 acc. to ČSN EN 1092-1 (2/2003) - plain flange	
Weld ends	Acc. to ČSN 13 1075	
Type of trim	One - three-step pressure reduction	
	Perforated plug - seat(cage), contoured plug for DN 15 and 25	
Flow characteristic	Linear, equal-percentage	
Leakage rate	Acc. to ČSN EN 1349 (5/2001) Class III, execution with higher tightness - Class V	
Packing	Graphite	

Range of Kvs values

DN	15 *)	25 **)	40	50	65	80	100	125	150
Multi-step press. red.	Kvs values [m³/h] - linear characteristic								
1	0.1 - 3.2	0.1 - 8.0	2.5 - 20	3.2 - 32	6.3 - 50	8.0 - 80	10 - 125	10 - 125	16 - 250
2	0.1 - 3.2	0.1 - 8.0	2.0 - 20	2.5 - 32	5.0 - 50	8.0 - 80	8.0 - 125	8.0 - 125	12.5 - 250
3	---	1.6 - 8.0	2.0 - 20	2.0 - 32	4.0 - 40	8.0 - 80	8.0 - 100	8.0 - 100	12.5 - 200
Multi-step press. red.	Kvs values [m³/h] - equal-percentage characteristic								
1	0.63 - 3.2	0.63 - 8.0	6.3 - 20	6.3 - 25	6.3 - 32	16 - 50	16 - 63	16 - 63	32 - 125
2	0.63 - 3.2	0.63 - 6.3	5.0 - 16	5.0 - 20	5.0 - 25	12.5 - 40	12.5 - 50	12.5 - 50	25 - 80
3	---	1.6 - 4.0	4.0 - 12.5	4.0 - 16	4.0 - 20	10 - 32	10 - 40	10 - 40	20 - 63

*) contoured plug

***) contoured plug for Kvs of 0,1 - 1,6 m3/h

Nominal values of Kvs are understood as multiples of 10 of the progression of selected numbers R10 (1.0; 1.25; 1.6; 2.0; 2.5;

3.2; 4.0; 5.0; 6.3; 8.0; 10.0). They are specified individually for every valve acc. to the customer's requirements and value within the appropriate range shown in the table above.

Dimensions and weights for the valve type RV 501 with weld ends

DN	PN 16	PN 25	PN 40	PN 63	PN 100	PN 160	PN 16 to 160							
	t	t	t	t	t	t	D	L	V ₁	V ₂	V ₃	H	m	
	[mm]	[mm]	[mm]	[mm]	[mm]	[mm]	[mm]	[mm]	[mm]	[mm]	[mm]	[mm]	[mm]	[kg]
15	2.6	2.6	2.6	2.6	2.6	2.9	21.3	220	30	246	130	16	6.5	
25	2.6	2.6	2.6	2.6	2.9	4.0	33.7	270	103	254	130	16	11	
40	2.6	2.6	2.6	2.9	3.6	5.0	48.3	300	129	265	130	25	22	
50	2.9	2.9	2.9	3.2	4.5	6.3	60.3	390	150	291	130	25	30	
65	3.2	3.2	3.2	3.6	5.0	7.0	76.1	450	175	310	130	25	45	
80	3.6	3.6	3.6	4.0	5.6	8.0	88.9	480	180	320	130	40	67	
100	4.0	4.0	4.0	5.0	7.0	10	114.3	580	204	345	130	40	78	
125	4.5	4.5	4.5	5.6	8	12.5	139.7	580	204	345	130	40	90	
150	5.0	5.0	5.0	7.0	10	14	168.3	720	264	453	190	63	220	

Control valve RV 501 with weld ends

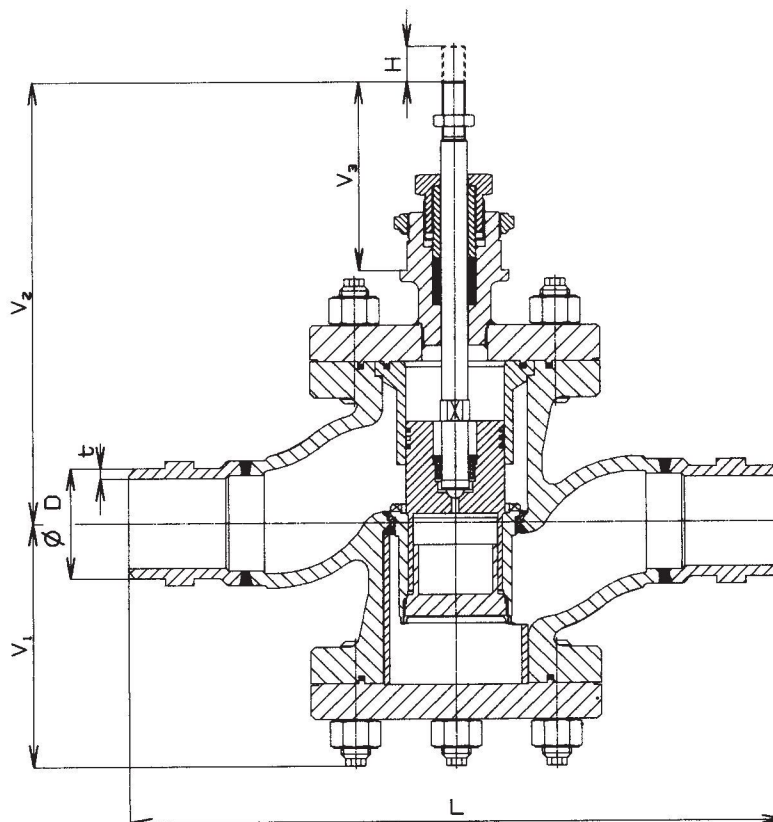

Dimensions and weights for the valve type RV 501 with flanges

DN	PN 16					PN 25					PN 40					PN 63				
	D ₁ [mm]	D ₂ [mm]	a [mm]	d [mm]	n [pcs]	D ₁ [mm]	D ₂ [mm]	a [mm]	d [mm]	n [pcs]	D ₁ [mm]	D ₂ [mm]	a [mm]	d [mm]	n [pcs]	D ₁ [mm]	D ₂ [mm]	a [mm]	d [mm]	n [pcs]
15	95	65	16	14	4	95	65	16	14	4	95	65	16	14	4	105	75	20	14	4
25	115	85	18	14	4	115	85	18	14	4	115	85	18	14	4	140	100	24	18	4
40	150	110	18	18	4	150	110	18	18	4	150	110	18	18	4	170	125	26	22	4
50	165	125	18	18	4	165	125	20	18	4	165	125	20	18	4	180	135	26	22	4
65	185	145	18	18	8	185	145	22	18	8	185	145	22	18	8	205	160	26	22	8
80	200	160	20	18	8	200	160	24	18	8	200	160	24	18	8	215	170	28	22	8
100	220	180	20	18	8	235	190	24	22	8	235	190	24	22	8	250	200	30	26	8
125	250	210	22	18	8	270	220	26	26	8	270	220	26	26	8	295	240	34	30	8
150	285	240	22	22	8	300	250	28	26	8	300	250	28	26	8	345	280	36	33	8

DN	PN 100					PN 160					PN 16 to 160							
	D ₁ [mm]	D ₂ [mm]	a [mm]	d [mm]	n [pcs]	D ₁ [mm]	D ₂ [mm]	a [mm]	d [mm]	n [pcs]	D ₃ [mm]	V ₁ [mm]	V ₂ [mm]	V ₃ [mm]	L [mm]	f [mm]	H [mm]	m [kg]
15	105	75	20	14	4	105	75	20	14	4	45	30	246	130	230	2	16	8
25	140	100	24	18	4	140	100	24	18	4	68	103	254	130	260		16	13
40	170	125	26	22	4	170	125	28	22	4	88	129	265	130	300		25	24
50	195	145	28	26	4	195	145	30	26	4	102	150	291	130	350		25	34
65	220	170	30	26	8	220	170	34	26	8	122	175	310	130	420		25	50
80	230	180	32	26	8	230	180	36	26	8	138	180	320	130	450		40	73
100	265	210	36	30	8	265	210	40	30	8	162 ¹⁾	204	345	130	520		40	86
125	315	250	40	33	8	315	250	44	33	8	188	204	345	130	520		40	86
150	355	290	44	33	12	355	290	50	33	12	218 ²⁾	264	453	190	680		63	240

¹⁾ for PN 16 ... 158 mm

²⁾ for PN 16 ... 212 mm

Control valve RV 501 with flanges

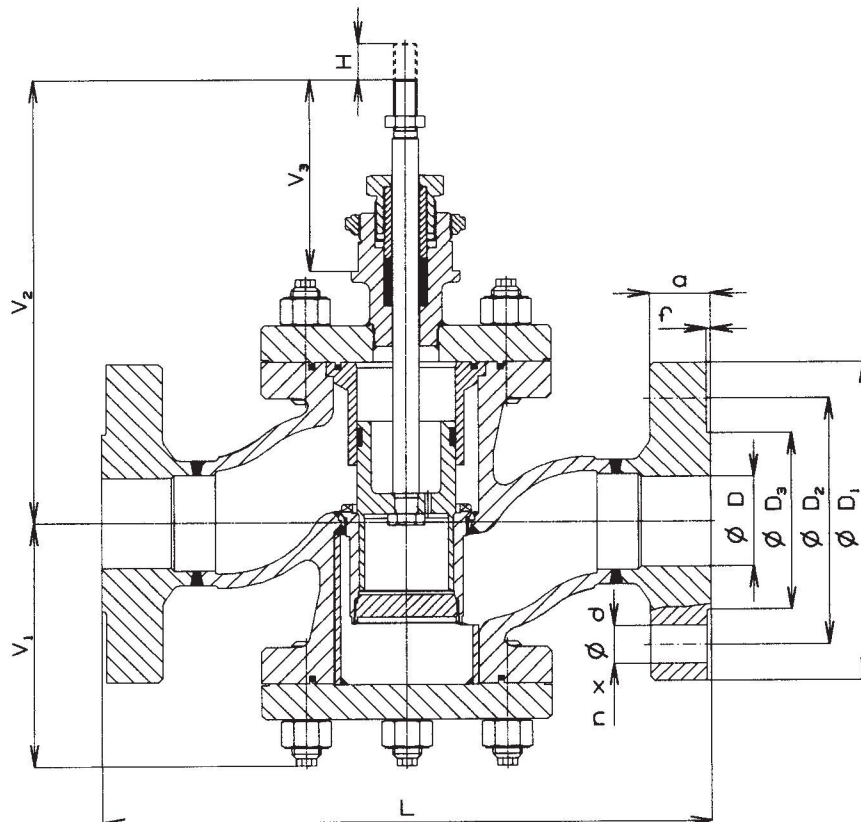

Valve complete specification No. for ordering RV 501

		XX	X X X	X X X	X X X X	X X	- XXX	/ XXX	- XXX
1. Valve	Control valve	RV							
2. Series	Control valve, straight-through		5 0 1						
3. Type of actuating	Electric actuator			E					
	Pneumatic actuator			P					
	Electric actuator Zepadyn			E N C					
	Electric actuator Modact MTR			E P D					
	Electric actuator Modact MT Control			E Y A					
	Electric actuator Modact MT			E Y B					
	Electric actuator Modact MOP 52 030			E Y E					
	Electric actuator Modact MOP Control 52 030			E Y F					
	Electric actuator Modact MOP 52 031			E Y G					
	Electric actuator Modact MOP Control 52 031			E Y H					
	Electric actuator Auma SA 07.1			E A A					
	Electric actuator Auma SA Ex 07.1			E A B					
	Electric actuator Auma SAR 07.1			E A C					
	Electric actuator Auma SAR Ex 07.1			E A D					
	Electric actuator Schiebel AB5			E Z E					
	Electric actuator Schiebel exAB5			E Z F					
	Electric actuator Schiebel rAB5			E Z G					
Electric actuator Schiebel exrAB5			E Z H						
Pneumatic actuator Foxboro PB 502			P F B						
Pneumatic actuator Foxboro PB 700			P F C						
Pneumatic actuator Foxboro PO 1502			P F D						
4. Connection	Flange with raised face				1				
	Flange with female face				2				
	Flange with plain face				3				
	Weld ends				4				
5. Body material <i>(operating temp. ranges are specified in parentheses)</i>	Cast steel 1.0619 (-20 to 400°C)				1				
	Alloy steel 1.7357 (-20 to 550°C)				7				
	Other material on request				9				
6. Packing	Graphite				5				
7. Multi-step pressure reduction	One-step pressure reduction				1				
	Two-step pressure reduction				2				
	Three-step pressure reduction				3				
8. Flow characteristic	Linear - Leakage rate class III.					L			
	Linear - Leakage rate class V.					D			
	Equal-percentage - Leakage rate class III.					R			
	Equal-percentage - Leakage rate class V.					Q			
9. No. of orifice plate	Without					0			
10. Nominal pressure	PN 16						16		
	PN 25						25		
	PN 40						40		
	PN 63						63		
	PN 100						100		
	PN 160						160		
11. Max. operating temp. °C	Acc. to process medium							XXX	
12. Nominal size	DN - acc. to the valve's execution								XXX

Ordering example: Two-way, control valve DN 80, PN 160, with electric actuator Modact MTN Control, body material: cast steel, weld ends, packing Graphite, two-step pressure reduction, linear flow characteristic is specified as follows: **RV 501 EYA 4152 L0 160/400-80.**

Note

In case of request, it is possible to deliver a different type of actuator.



Electric actuator Zepadyn 670 (Zepadyn 524 60) ZPA Nová Paka

Technical data

Type	Zepadyn 670 XXX (Zepadyn 524 60.XXXX)
Marking in valve specification No.	ENC
Voltage	230 V or 24 V
Frequency	50 Hz
Power consumption	40 VA
Control	3 - position control, 0 - 10 V, 0(4) - 20 mA
Nominal force	10000 N
Stroke	16, 25 mm
Enclosure	IP 65 (type 524 60 IP 54)
Process medium max. temp.	Acc. to used valve
Ambient temperature range	-25 to 55°C
Ambient humidity limit	10 - 100 % with condensation
Hmotnost	11 kg

Wiring diagrams

Feeding voltage 230 V/50 Hz

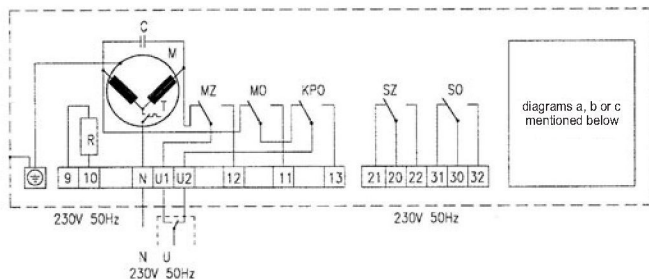

Execution with positioner, feeding voltage 230 V/50 Hz

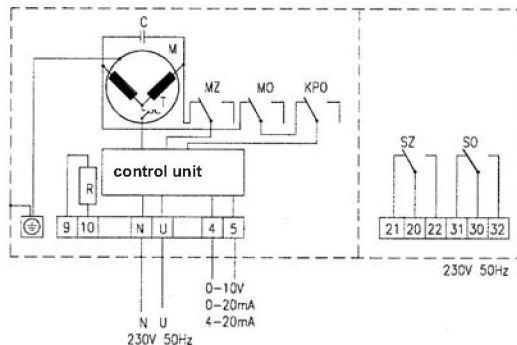

Feeding voltage 24 V/50 Hz

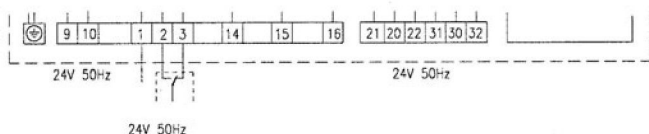

Execution with positioner, feeding voltage 24 V/50 Hz

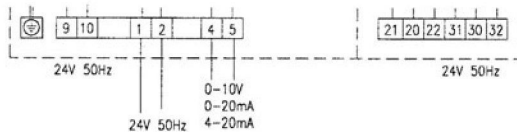

Execution:
with resistance transmitter with capacity position transmitter

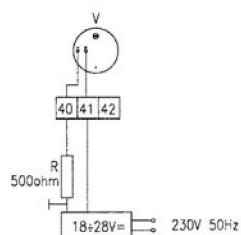
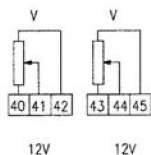

with converter
4-20mA

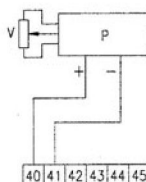

Specification of actuator Zepadyn 670 (marking valid from 1. 1. 2001)

		Zepadyn 670				X	X	X	/
Feeding voltage AC	230 V (50/60 Hz)					1			
	24 V (50/60 Hz)					2			
Nominal force [kN]	10						4		
Running speed mm.min ⁻¹	6,3							1	
	16							2	
	25							3	
	32							4	
Additional accessory	Positioner 0-1 V, 0-10 V, 0(4)-20 mA - without R2								OP1
	Signalization switches SO and SZ								S1
	1 resistance transmitter 100Ω								R1
	2 resistance transmitters 100Ω - without OP1, I1 and C1								R2
	Converter 4 - 20 mA - without R2 and C1								I1
	Capacity transmitter CPT1 - without R2 and I1								C1
	Heater								T1
Connection - column pitch 132, M20, coupling M10x1, M16x1,5									P3

Basic version : 3-position control, hand wheel, limit switches for Open and Closed positions, without transmitter and connection parts.

Specification of actuator Zepadyn 524 60 (marking valid till 31. 12. 2000)

		Zepadyn 524 60.				X	X	X	X	/
Feeding voltage 230 V/50 Hz	Nominal force kN	10				3	X	X	X	
	Resetting speed mm.min ⁻¹	6,3				X	0	X	X	
		16				X	1	X	X	
		25				X	2	X	X	
Feeding voltage 24 V/50 Hz	Nominal force kN	10				7	X	X	X	
	Resetting speed mm.min ⁻¹	6,3				X	0	X	X	
		16				X	1	X	X	
		25				X	2	X	X	
Transmitter execution	Without transmitter					0	X			
	Single transmitter 100Ω					1	X			
	Double transmitter 2x100Ω					2	X			
	Other (e.g. feedback of 4 - 20 mA)*					9	X			
Connection dimensions									1	
Execution	With capacity transmitter CPT1/A									C1
	With positioner									OP1
	With converter 4-20 mA									I1

*) On request

Dimensions of actuator Zepadyn

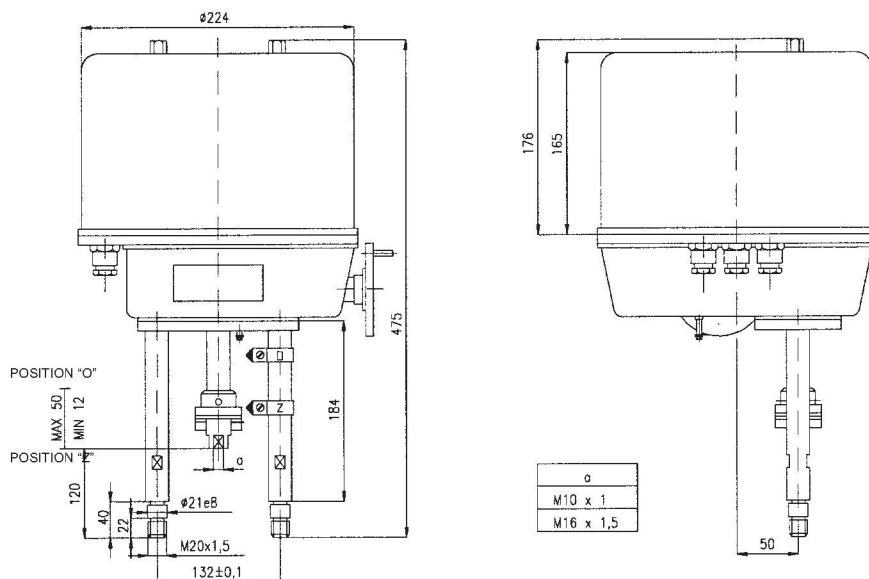



**Electric actuator Modact MTR
Regada**

Technical data

Type	Modact MTR
Marking in valve specification No.	EPD
Voltage	230 V
Frequency	50 / 60 Hz
Motor power	16 or 25 W
Control	3 - pos. c. (in connection with NOTREP positioner - continuous)
Nominal force	10, 16, 25 kN
Travel	12,5 to 100 mm
Enclosure	IP 54 (IP 65 on request)
Process medium max. temperature	Acc. to used valve
Ambient temperature range	-25 to 50°C
Ambient humidity limit	90 %
Weight	27 to 31 kg

Dimensions of Modact MTR

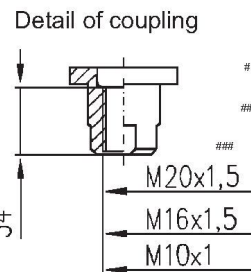
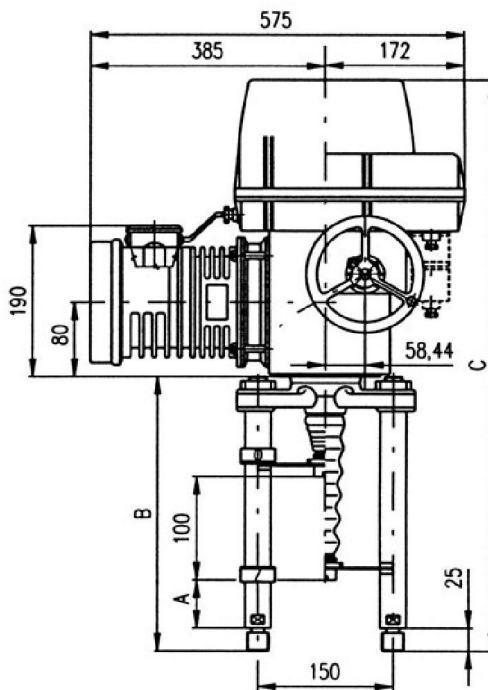
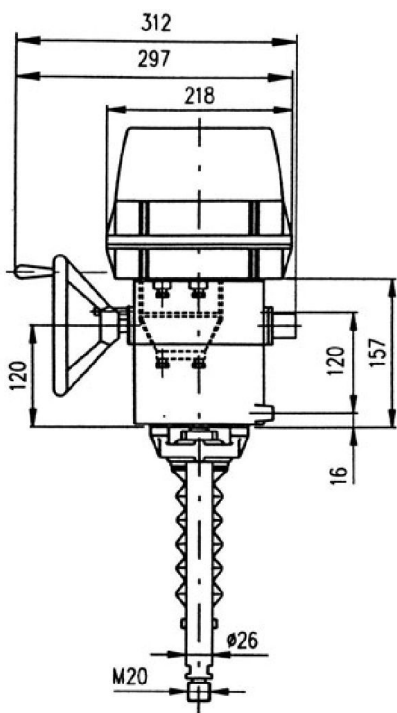

columns	with ball bolt			for valves
	A	B	C	
P-1045a/H	130	400	729	RV 501 DN 15 ÷ 125
P-1045a/E	74	344	673	RV 501 DN 150

#) RV 501, DN 150
 ##) RV 501, DN 40 ÷ 125
 ###) RV 501, DN 15 and 25

Specification of Modact MTR

Electric actuator MTR, linear					52 420.	X	-	X	X	X	X	X	/	X	X				
Mild up to hot dry with temperature range (-25 °C to +50 °C)					0														
Electric connection		Voltage			Wiring diagram														
To terminal board		230 V AC			Z296														
To connector									9										
Screw version		Switching-off thrust ¹⁾²⁾	Rated operating speed	Operating speed	Electric motor														
					Power	Speed	Current												
ball screw	16 000/32-G	10.0 - 16.0 kN	32 mm/min.	38 - 32 mm/min.	16 W	1 150	0.31 A							E					
	25 000/32-G	10.0 - 25.0 kN	32 mm/min.	38 - 32 mm/min.	25 W	1 250	0.41 A							G					
	16 000/50-G	10.0 - 16.0 kN	50 mm/min.	60 - 50 mm/min.												H			
Control board version			Operating stroke		Wiring diagram														
Electromechanical control board - without local control			16 mm		Z298									B					
			25 mm														C		
			40 mm															E	
			63 mm																F
Transmitter			Connection	Output	Wiring diagram														
Without transmitter			—	—	—										A				
Resistive	Single		—	—	1x100 Ω	Z5a									B				
	Double				2x100 Ω	Z6a										C			
	Single				1x2000 Ω	Z5a											F		
	Double				2x2000 Ω	Z6a											P		
Resistive with current converter	Without power supply		2-wire	4 - 20 mA	Z10a										S				
	With power supply				Z269a												Q		
	Without power supply		3-wire	0 - 20 mA	Z257a											T			
	With power supply				Z260a												U		
	Without power supply				4 - 20 mA			Z257a									V		
	With power supply				4 - 20 mA			Z260a									W		
	Without power supply				0 - 5 mA			Z257a									Y		
	With power supply				0 - 5 mA			Z260a									Z		
Capacitive CPT	Without power supply		2-wire	4 - 20 mA	Z10a										I				
	With power supply				Z269a												J		
Mechanical connection	Connecting height / stroke		Pillar spacing / Bore of flange	Thread of stem ³⁾	Dimensional drawing														
Columns	74/100		150/ —	M20x1.5 M16x1.5, M10x1	P-1045a/E										B				
	130/100				P-1045a/H												C		
Additional equipment					Wiring diagram														
Without additional equipment; adjusted max. switching-off thrust from range																0 1			
A	2 additional position switches S5,S6				Z298											0 2			
B	Adjustment of switching-off thrust for required value															0 3			

Combinations available and specification codes: A+B = 07

Notes:

- 1) State the switching-off thrust in your order by words. If not stated it is adjusted to the maximum rate of the corresponding range. The load torque equals minimally the maximum switching-off thrust of the choosing range multiplied by 1.3.
- 2) The maximum load thrust equals the max. Switching-off thrust multiplied by:
 - 0.8 for duty cycle S2-10 min., Or S4-25%, 6 - 90 cycles per hour
 - 0.6 for duty cycle S4-25%, 90 - 1200 cycles per hour
- 3) The thread in the coupling is to be specified in the order by words.

Wiring diagram of actuator Modact MTR

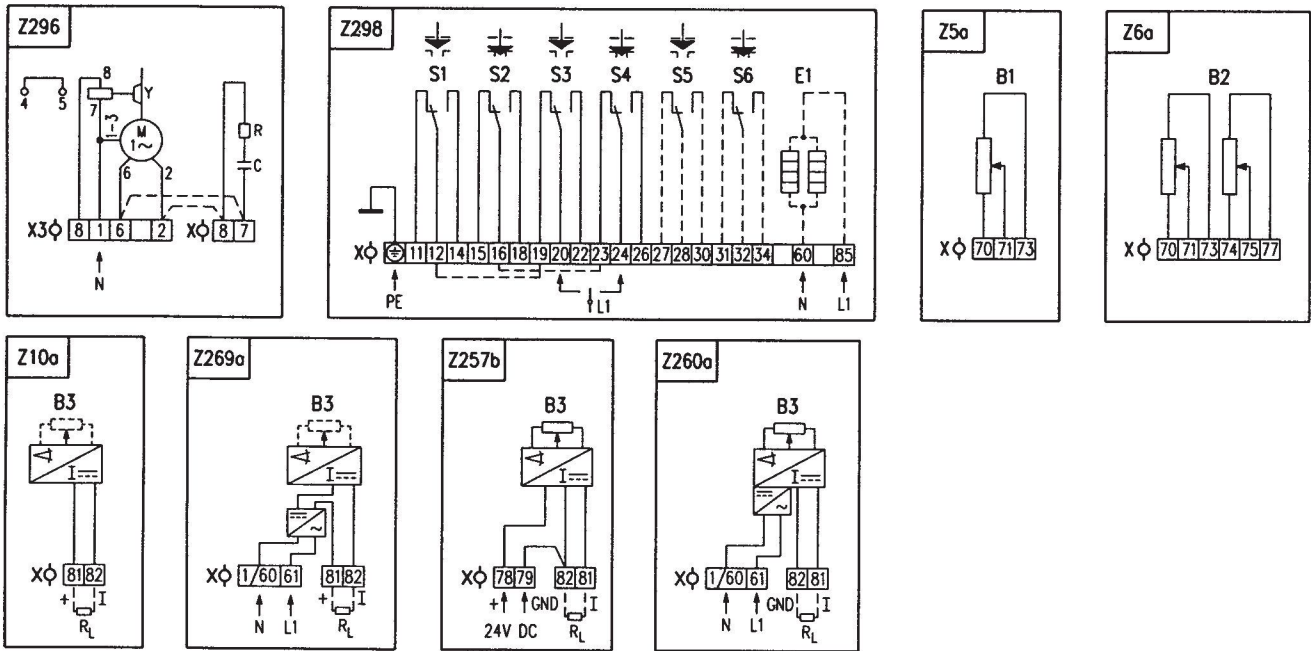

Notes:

1. For the EA version with connection to the terminal board, the terminal 1/60 (the wiring diagrams Z269a and Z260a) is leaded out to the terminal No. 1.
2. For EA version with connection to the terminal board the actuator is not equipped by the jumper X3:6-X:7 and X3:2-X:8 (Z296) from manufacturing plant (it is necessary to connect it by customer).

Legend:

Z5a connection of single resistive transmitter
 Z6a connection of double resistive transmitter
 Z10a connection of resistive with current converter of capacitive transmitter - 2-wire without supply
 Z257b connection of resistive transmitter with current converter - 3-wire
 Z260a connection of resistive transmitter with current converter - 3-wire with power supply
 Z269a connection of resistive transmitter with current converter or capacitive transmitter - 3-wire with power supply
 Z296 connection of 1-phase electric motor
 Z298 connection of thrust and position switches and space heater

B1 resistive transmitter (potentiometer) single
 B2 resistive transmitter (potentiometer) double
 B3 capacitive transmitter
 S1 thrust switch "open"
 S2 thrust switch "closing"
 S3 position switch "open"
 S4 position switch "closed"
 S5 additional position switch "open"
 S6 additional position "closed"
 M motor
 C capacitor
 Y motor's brake
 E1 space heater
 X terminal board
 X3 electric motor's terminal board
 I/U input (output) current (voltage) signals
 R reducing resistor
 R_L loading resistor



Electric actuators Modact MTN and Modact MTN Control ZPA Pečky

Technical data

Type	Modact MTN Control	Modact MTN
Marking in valve specification No.	EYA	EYB
Voltage	3 x 220 V / 400 V (3 x 220 V/380V)	
Frequency	50 Hz	
Motor power	See specification table	
Control	3 - position control or continuous	
Nominal force	15000 and 25000 N	
Travel	10 to 100 mm	
Enclosure	IP 55	
Process medium max. temperature	Acc. to used valve	
Ambient temperature range	-25 to 55 °C	
Ambient humidity range	5 - 100 % with condensation	
Weight	45 kg	

Wiring diagram of actuator Modact MTN

Execution - terminal board

Position transmitter : resistance 2x100 W or without

Position transmitter : capacity CPT 1 1/A 4 - 20 mA

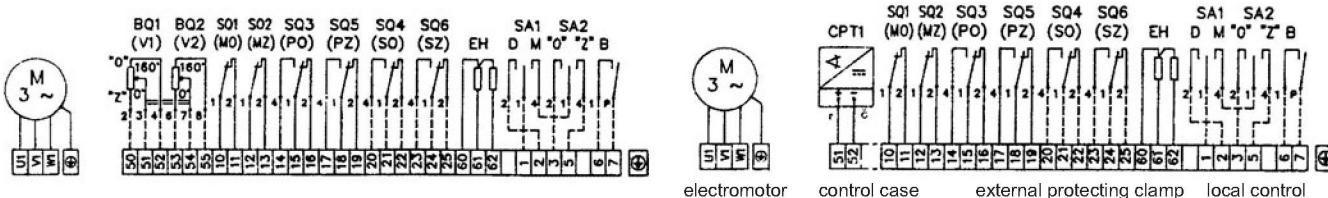

Wiring diagram of actuator Modact MTN Control

With current transmitter, built-in contactor combination, brake BAM and positioner.

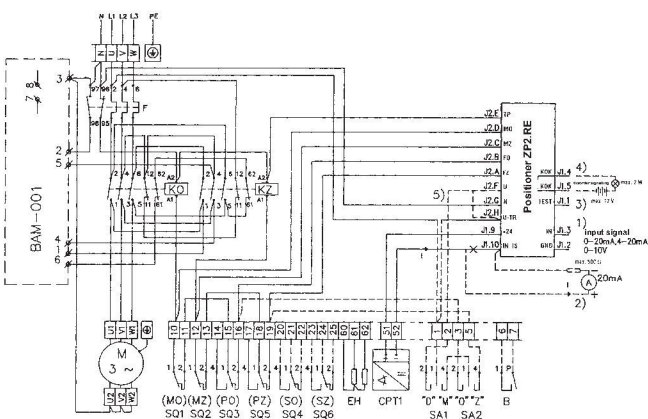

- SQ1 (MO) power switch in "opening" direction
- SQ2 (MZ) power switch in "closing" direction
- SQ3 (PO) limit switch in "opening" direction
- SQ5 (PZ) limit switch in "closing" direction
- SQ4 (SO) signalisation switch in "opening" direction
- SQ6 (SZ) signalisation switch in "closing" direction
- EH heaters 2 x TR 551 10k/A
- CPT1 capacity position transmitter CPT1/A 4 - 20 mA
- BAM-001 dynamic brake
- KO contactor in "opening" direction
- KZ contactor in "closing" direction
- F thermal relay
- SA1 control switch "local - remote"
- SA2 switch "open - close"
- BQ1, BQ2 position transmitter 2 x 100 W
- ZP2.RE electronic positioner

Connection dimensions - details of additional specification 52 442

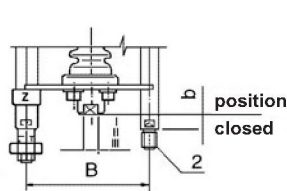

Columns pitch	B	150
Position "closed"	b	74
	g	130
	I	M 20x1,5
Clutch thread	II	M 16x1,5
	III	M 10x1

Execution	Specification No.	
	basic	additional
Bb2II	52 442	XMXX RV 501, DN 40÷125
Bb2III	52 442	XPXX RV 501, DN 15, 25
Bg2I	52 442	XRXX RV 501, DN 150

Specification of actuators Modact MTN and Modact MTN Control

Basic equipment :	2 power switches MO, MZ	1 position transmitter - resist. 2x100 W or cap. CPT1/A
	2 limit switches PO, PZ	2 limit switches PO, PZ
	2 limit and signalisation switches SO, SZ	2 limit and signalisation switches SO, SZ

Basic technical data :

Typ	Power switch setting range kN	Direct power kN	Resetting speed mm.min ⁻¹	Travel mm	Electromotor				Weight		Specification No.	
					Power W	rpm	In (400V) A	Iz In	Aluminium	Cast	Basic	Additional
MT 15	11,5 - 15	17	50	10 - 100	180	900	0.67	2.5	33	45	52 442	XX0X
			80		180	900	0.67	2.5				XX1X
			125		250	1380	0.77	3.4				XX3X
			36		120	660	0.67	2.2				XX2X
			27		120	660	0.67	2.2				XXAX
MT 25	15 - 25	32,5	50	10 - 100	180	900	0.67	2.5	33	45		XX4X
			80		180	900	0.67	2.5				XX5X
			125		250	1380	0.77	3.4				XX6X
			36		120	660	0.67	2.2			XX7X	
			27		120	660	0.67	2.2			XX8X	

Execution, electric connection :

Via terminal board		6XXX	
With conector KBSN (for Modact MTN execution only)		7XXX	
Transmitter for Modact MTN	Capacity transmitter CPT 1/A 4 - 20 mA	XXX0	
	Resistance transmitter 2 x 100 Ω	XXX2	
Additional electric equipment		With resistance transmitter 2 x 100 Ω	
Modact MTN execution	With local control - terminal board	XXX3	
	With unlock control - conector KBNS	XXX3	
Modact MTN Control execution (with built-in contactor combination)	Without local control	Without brake BAM and positioner	XXX4
		With brake BAM, without positioner	XXX5
		With brake BAM and with positioner	
	With local control	Without brake BAM and positioner	XXX7
		With brake BAM, without positioner	XXX8
With brake BAM and positioner			

Note : When execution with flasher is requested, please specify this requirement in writing - execution with flasher.

Dimensions of actuator Modact MTN Dimensions of actuator Modact MTN Control

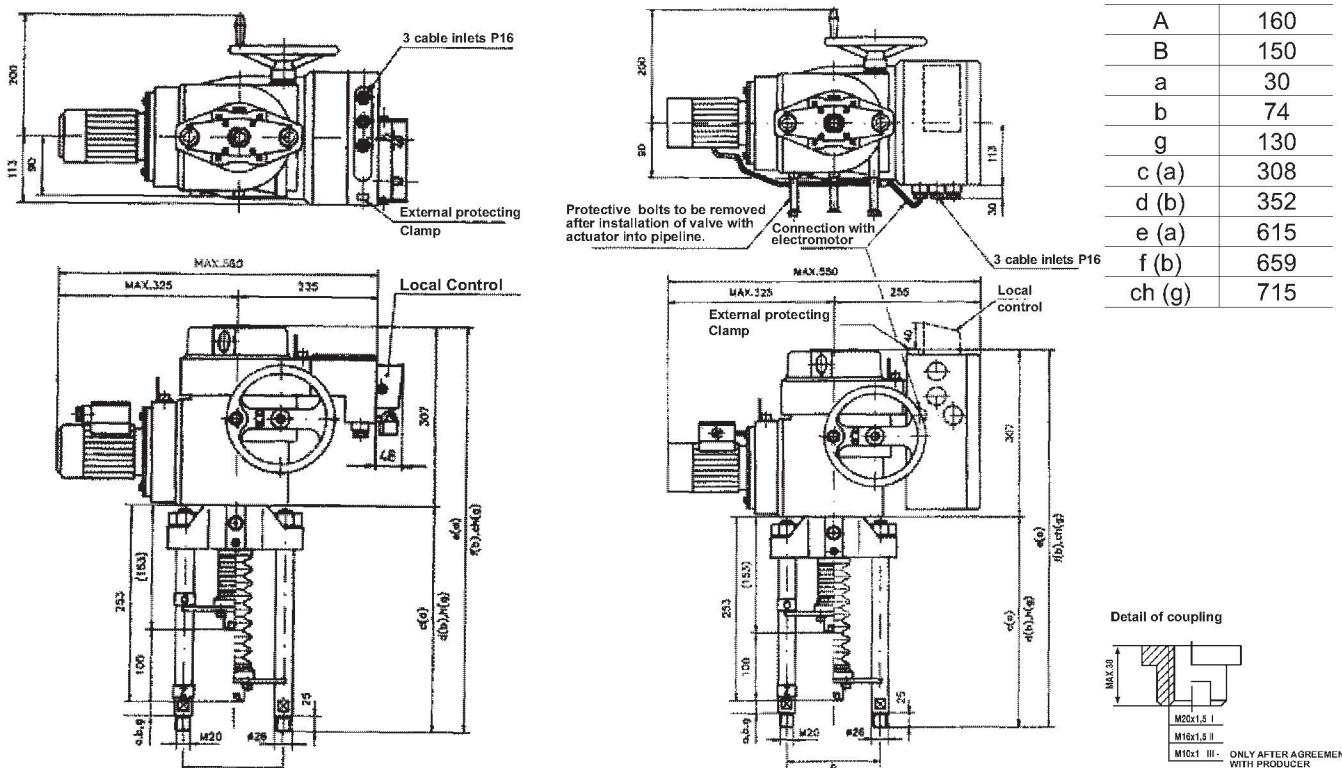



Electric actuators Modact MOP and Modact MOP Control ZPA Pečky

Technical data

Type	52 030 MOP	52 030 MOP Control	520 31 MOP	52 031 MOP Control
Marking in valve specification No.	EYE	EYF	EYG	EYH
Voltage	3x 230/400 V			
Frequency	50 Hz			
Motor power	See specification table			
Control	3 - position control or continuous			
Nominal force	20 Nm			
Travel	Acc. to given stroke			
Enclosure	IP 67			
Process medium max. temperature	Acc. to used valve			
Ambient temperature range	acc. to ČSN 33 2000-3, class AA7, AB7, AC1, AD5, AE5, AF2, AG2, AH2, AK2, AL2, AM2, AN2, AP3, BA4, BC3			
Working condition	Loading S2 acc. to ČSN EN 60 034-1			
Weight	23 - 36 kg		33 - 59 kg	

Dimensions of Modact MOP

DIMENSIONAL DRAWING OF ACTUATORS MODACT MOP

52 030 a 52 031 EXECUTION WITH TERMINAL BOARD

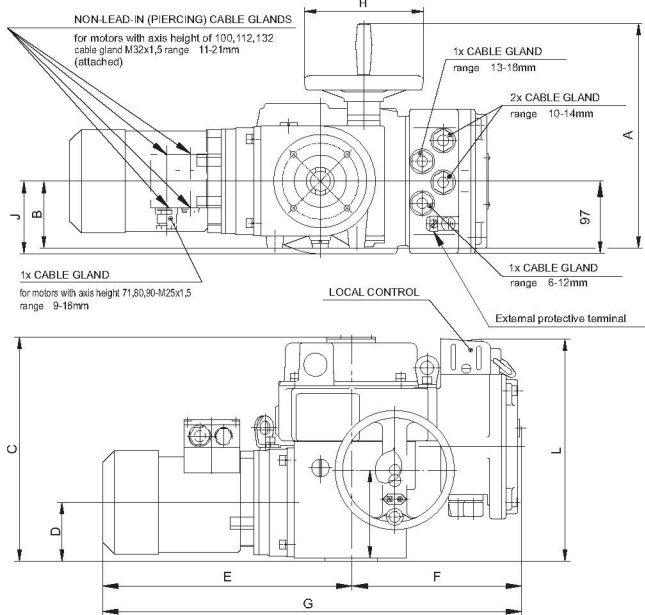

DIMENSIONAL DRAWING OF ACTUATORS MODACT MOP

52 030 a 52 031 EXECUTION WITH CONECTOR

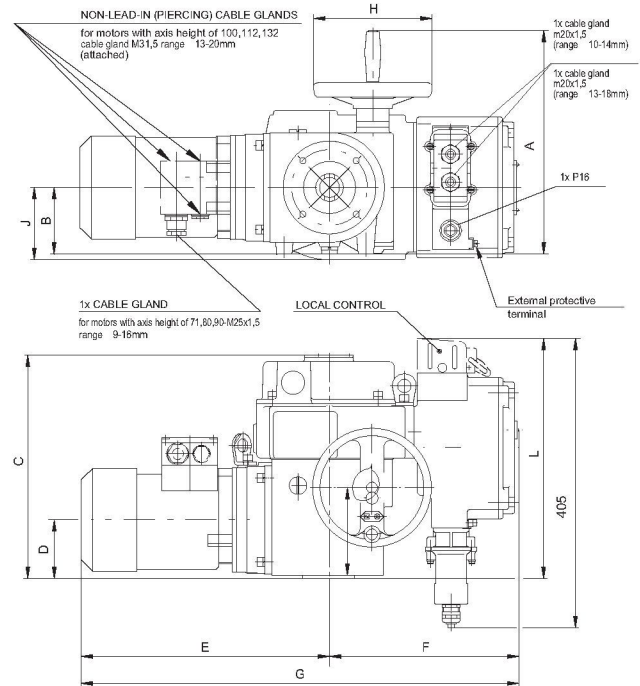

Type marking	A	B	C	D	E	F	G	H	J	K	L
52 030	305	90	300	78	334	228	562	160	99	120	300
52 031	376	120	328	92	436	228	664	200	-	144	328

Type marking	A	B	C	D	E	F	G	H	J	K	L
52 030	305	90	300	78	334	258	592	160	99	120	325
52 031	376	120	328	92	436	258	694	200	-	144	350

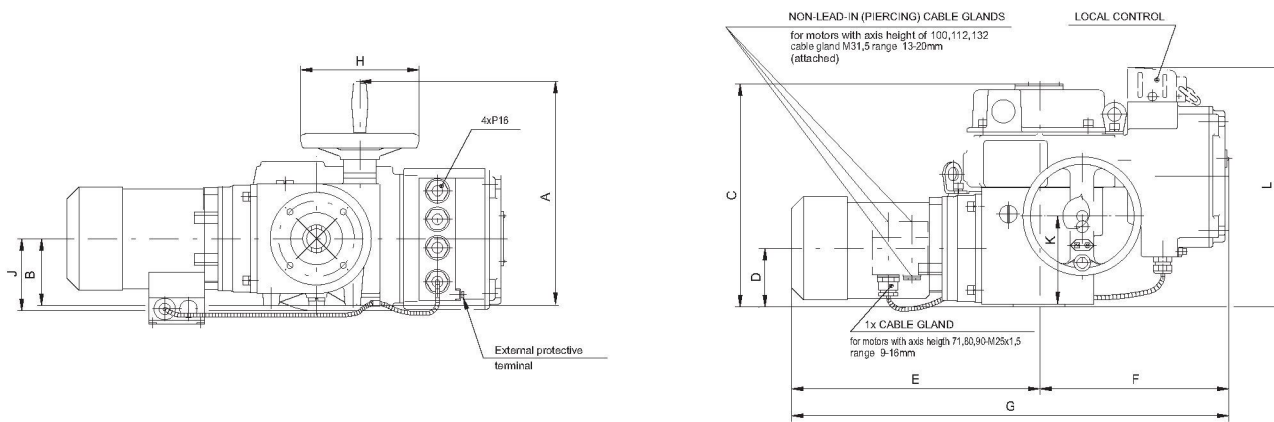

Type marking	A	B	C	D	E	F	G	H	J	K	L
52 030	305	90	300	78	334	258	592	160	99	120	325
52 031	376	120	328	92	436	258	694	200	-	144	328

Specifikace pohonu Modact MOP

								XX XXX		X	X	X	X	X														
Connection dimensions	Output shaft type A	Via terminal board								5																		
		With connector								F																		
Local control, position indicator																												
Resistance transmitter or execution without transmitter		Without local control, without position indicator												1														
		Local control												4														
		Local control for actuators Modact MOP Control														7												
Capacity transmitter CPT 1/A		Without local control, without position indicator												B														
		Local control												E														
		Local control for actuators Modact MOP Control														H												
Type marking	Moment		Running speed	Stroke	Electromotor				52 030	J	0	1	2	3	4	5	K	6	7	8	0	1	2	3	4	E	5	F
	Tripping	Driving			Power	rpm	I _n (400V)	I ₂ / I _n																				
	(Nm)	(Nm)			(kW)	(1/min.)	(A)	(-)																				
MOP 40/70 - 7	20-40	70	7	0,05	650	0,42	1,6	52 030	J	0	1	2	3	4	5	K	6	7	8	0	1	2	3	4	E	5	F	
MOP 40/65 - 9		65	9	0,06	830	0,34	2,0																					
MOP 40/55 - 15		55	15	0,09	870	0,47	2,0																					
MOP 40/75 - 25		75	25	0,18	1350	0,56	3,0																					
MOP 40/65 - 40		65	40	0,25	1350	0,76	3,0																					
MOP 40/50 - 50		50	50	0,25	2830	0,68	4,0																					
MOP 40/60 - 80		60	80	0,37	2740	1,00	3,5																					
MOP 80/135 - 7		40-80	135	7	0,09	630	0,36																					2,2
MOP 80/140 - 9	140		9	0,12	890	0,60	2,5																					
MOP 80/135 - 15	135		15	0,18	835	0,62	2,3																					
MOP 80/105 - 25	105		25	0,25	1350	0,76	3,0																					
MOP 100/130 - 9	63-100	130	9	0,12	890	0,60	2,5	52 031	0	1	2	3	4	E	5	F												
MOP 100/130 - 15		130	15	0,25	850	0,78	2,7																					
MOP 100/150 - 25		150	25	0,37	920	1,20	3,1																					
MOP 100/170 - 40		170	40	0,55	1395	1,45	3,9																					
MOP 100/150 - 63		150	63	0,75	1395	1,86	4,0																					
MOP 100/200 - 80		200	80	1,1	2845	2,40	6,1																					
MOP 100/150 - 100		150	100	1,1	1410	2,65	4,3																					
MOP 100/150 - 145		150	145	1,5	2860	3,30	5,5																					

the table continues on next page

		XX XXX	X	X	X	X	X	
Signalization, position transmitter, blinker								
Only for actuators Modact MOP	Without signalisation, position transmitter and blinker						0	
	Position transmitter						1	
	Signalization switches						2	
	Signalization switches and position transmitter						3	
	Blinker						4	
	Position transmitter, blinker						5	
	Signalization switches and blinker						6	
	Signalization switches, position transmitter, blinker						7	
Signalization, position transmitter, blinker								
Only for actuators Modact MOP Control	Complete equipment Sch P-0781	Position transmitter					A	
		Signalization switches and position transmitter					B	
		Position transmitter, blinker					C	
		Signalization switches, position transmitter and blinker					D	
	Without positioner	Without signalization, without posit. transmitter and blinker						E
		Position transmitter						F
		Signalization switches						G
		Signalization switches and position transmitter						H
		Blinker						I
		Position transmitter, blinker						J
		Signalization switches, blinker						K
		Signalization switches, position transmitter and blinker						L
	Without positioner and brake BAM	Without signalization, without position transm. and blinker						M
		Position transmitter						N
		Signalization switches						O
		Signalization switches and position transmitter						P
		Blinker						R
		Position transmitter, blinker						S
		Signalization switches, blinker						T
		Signalization switches, position transmitter and blinker						U
This mark is valid for the the types of the actuators							P	



**EAA, EAB
EAC, EAD**

**Electric actuators SA 07.1,
SA Ex 07.1, SAR 07.1, SAR Ex 07.1
Auma**

Technical data

Type	SA 07.1	SA Ex 07.1	SAR 07.1	SAR Ex 07.1
Marking in valve's specification No.	EAA	EAB	EAC	EAD
Voltage	380 or 400 V			
Frequency	50 Hz			
Motor power	See specification table			
Control	3 - position control or with signal 4 - 20 mA			
Nominal force	20 Nm ~ 10 kN; 25 Nm ~ 12,5 kN; 30 Nm ~ 15 kN			
Travel	Acc. to the valve stroke 16, 25, 40, 63 mm			
Enclosure	IP 67			
Process medium max. temperature	Acc. to used valve			
Ambient temperature range	-25 to 80 °C	-25 to 40 °C	-25 to 60 °C	-25 to 40 °C
Ambient humidity limit	100 %			
Weight	20 kg			

Specification of Auma actuators

Type	Control	SA	X	XX	07.1
Duty	ON - OFF	SA	R		
Execution	Normal				
	Non-explosive			Ex	
Actuator's size					07.1

Output drive type A (thread TR 16x4 LH, flange size F07 for RV 501 DN 50+100; thread TR 20x4 LH, flange F10 for RV 501 DN 150)

Output speed (rpm)	Tripping torque	SA 07.1	SA Ex 07.1	SAR 07.1	SAR Ex 07.1
		SAEX07.1	SAREx07.1		
4	10-30 Nm 15-30 Nm	10-30 Nm 15-30 Nm	10-30 Nm 15-30 Nm	0,025	0,025
5,6				0,025	0,025
8				0,045	0,045
11				0,045	0,045
16				0,09	0,09
22				0,09	0,09
32				0,18	0,18
45				0,18	0,18

Accessories

- 2 TANDEM switches
- Gearing for signalisation of position
- Mechanical position indicator
- Potentiometer 1x200 Ω
- Electronic position transmitter RWG (potentiometer included), 4 - 20 mA, 2-wire
- Electronic position transmitter RWG (potentiometer included), 4 - 20 mA, 3/4-wire
- Inductive position transmitter IWG, 4 - 20 mA
- AUMATIC - for continuous control (specification of accessories acc. to catalogue of producer)
- Other accessories acc. to catalogue of producer of actuators.

Dimensions of Auma actuators

Normal execution

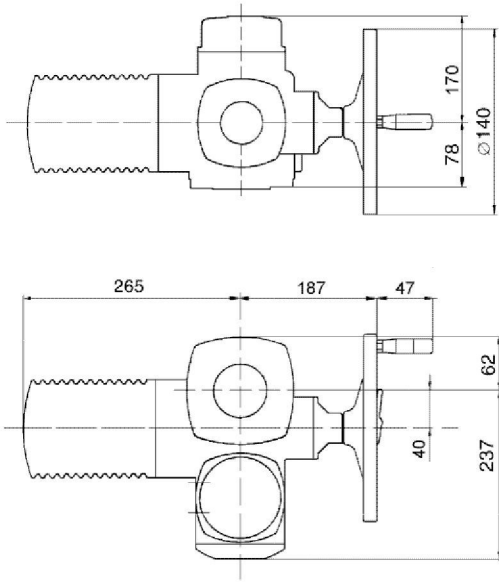

Ex execution

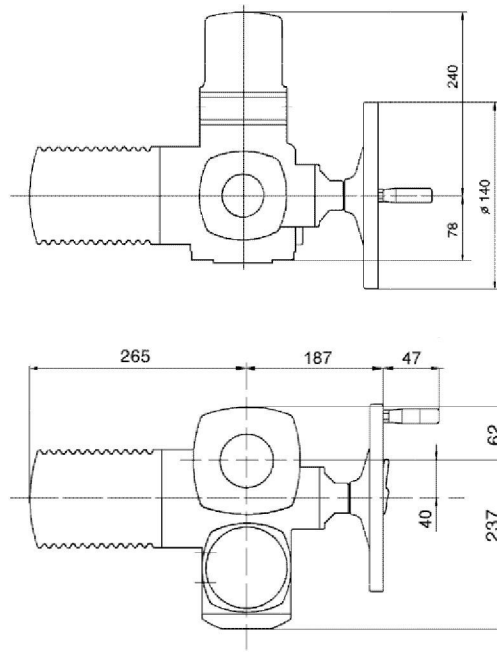

Version with AUMATIC

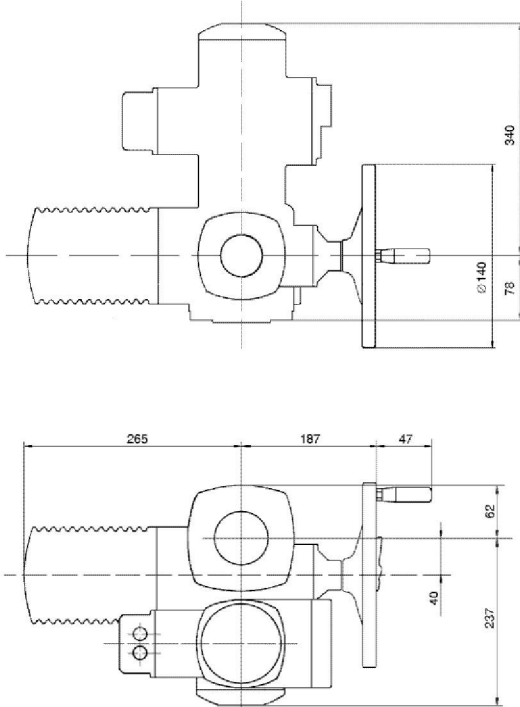

Output shaft type A, flange F07, (F10)

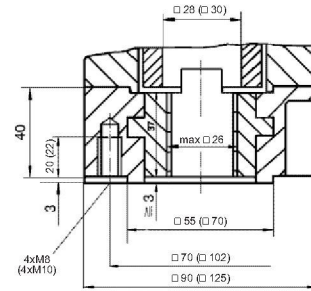

Attachement yoke

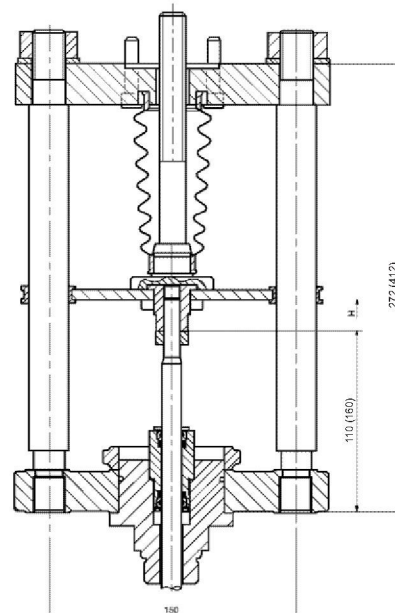

The values in parentheses apply to RV 501 DN 150



**EZE, EZF
EZG, EZH**

**Electric actuators ...AB5
Schiebel**

Technical data

Type	AB5	exAB5	rAB5	exrAB5
Marking in the valve's specification No.	EZE	EZF	EZG	EZH
Voltage	400 / 230 V; 230 V	400 / 230 V	400 / 230 V; 230 V	400 / 230 V
Frequency	50 Hz			
Motor power	See specification table			
Control	3 - position control or with signal 4 - 20 mA			
Nominal force	20 Nm ~ 10 kN; 30 Nm ~ 15 kN			
Stroke	Acc. to valve's stroke 16, 25, 40, 63 mm			
Enclosure	IP 66	IP 65	IP 66	IP 65
Process medium max. temperature	Acc. to used valve			
Ambient temperature range	-25 to 80 °C	-20 to 40 °C	-25 to 80 °C	-20 to 40 °C
Ambient humidity limit	90 % (tropical version 100 % with condensation)			
Weight	16 kg	12 kg	16 - 18 kg	16 kg

Specification of actuators

Execution		Non-explosive		XX	X	AB5	A	X	+	XXX			
		Normal		Ex									
Duty		Control			r								
		ON - OFF											
Actuator's size						AB5							
Output drive type (thread TR 16x4 LH, connection flange F07, thread TR 20x4 LH, flange F10)							A						
Output speed (rpm)	Tripping torque	AB5	rAB5	AB5		rAB5		exAB5	exrAB5	Motor power [kW]			
		exAB5	exrAB5	400/230V	230V	400/230V	230V	400/230V	400/230V				
		10-60 Nm	10-30 Nm	0,09	0,09	0,09	0,09	0,09	0,09				2,5
				0,12	0,12	0,12	0,12	0,12	0,12				5
				0,09	0,12	0,09	0,09	0,09	0,09				7,5
				0,12	0,25	0,12	0,12	0,18	0,18				10
				0,18	0,25	0,18	0,18	0,18	0,18				15
				0,18	0,55	0,18	0,18	0,37	0,37				20
				0,37	0,75	0,37	0,37	0,37	0,37				30
0,37	1,10			0,37	0,37	0,37	0,37		40				
Accessories		Potentiometer 1x1000 Ω								F			
		Double potentiometer								FF			
		Electronic transmitter 4 - 20 mA								ESM21			
		Positioner ACTUMATIC R								CMR			

Dimensions of actuators ...AB5

Actuator...AB5

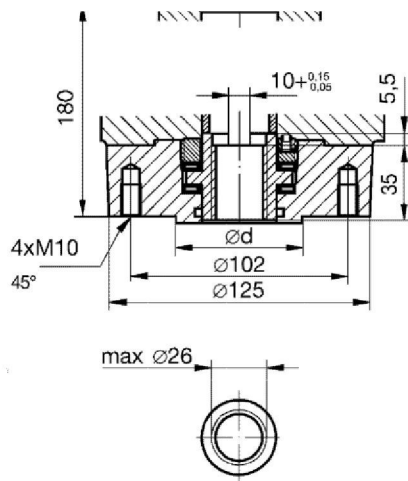
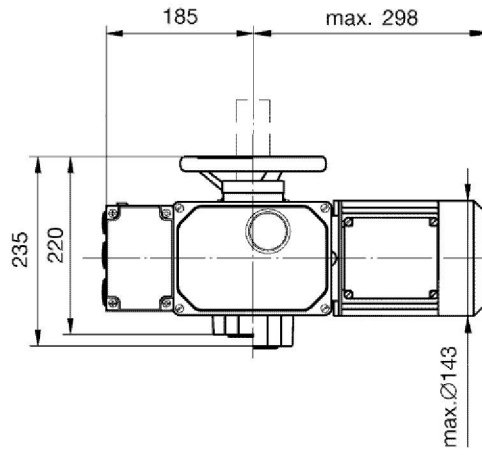
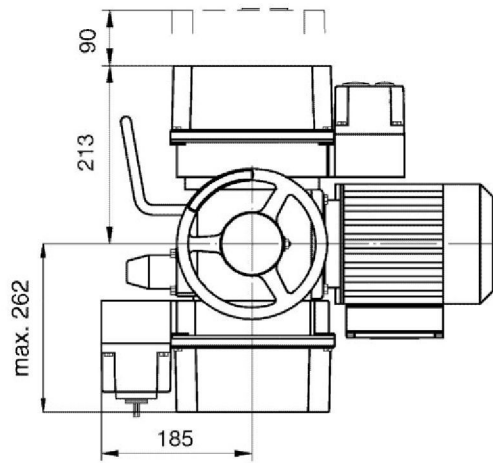

Attachement yoke

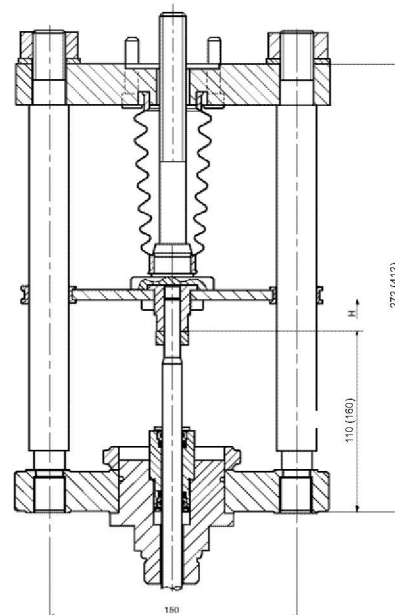

The values in parentheses apply to RV 501 DN 150



Pneumatic actuators Foxboro

Technical data

Type	PB 502	PB 700	PO 1502
Marking in valve specification No.	PFB	PFC	PFD
Feeding pressure	0,6 Mpa max .		
Function	Fail to open	Fail to close	Fail to open
Control	Pneumatic signal of 20 - 100 kPa Current signal of 0(4) - 20 mA		
Nominal force	According to table of nominal force values		
Stroke	40 mm	20 a 40 mm	80 mm
Enclosure	IP 54		
Process medium max. temperature	According to used valve		
Ambient temperature range	-40 to 80°C		
Ambient humidity limit	95 %		
Weight	See table of dimensions		

Accessories

Electropneumatic positioner (analogous) type SRI 990	Device with electric input of 4 to 20 mA and outlet of controlling air into actuator. It is adjusted by switches and potentiometers.
Electropneumatic positioner (intelligent) type SRD 991	Device with electric input of 4 to 20 mA and outlet of controlling air into actuator. It is adjusted by PC and special software. Communication HART, Fieldbus Foundation, PROFIBUS.
Electropneumatic positioner (digital) type SRD 991 - D	Device with electric input of 4 to 20 mA and outlet of contr. air into actuator. It is adjusted by a local keyboard and diods, possibly on display.
Pneumatic positioner type SRP 981	Device with pneumatic input of 20 to 100 kPa to control the pneumatic actuators with pneumatic control signal
Signalisation switches type SGE 985	Adjustable end position switches
Air set type A 3420	Reduces control air pressure to a value required
Electropneumatic positioner type SRI 986	Analog positioner with input signal of 4 (0) - 20 mA

Operating conditions

Pneumatic actuators FOXBORO can operate with extremely high ambient temperatures with unique resistance to shock loads. They excel with resistance to vibrations and reached 10⁸ of cycles in operation. It is possible to deliver the actuator with both fail to open and fail to close function, possibly with a position blocking (air lock) upon feeding pressure air supply failure. Various accessories can be delivered together with the actuator.

Direct and indirect functions

Direct function ensures that actuator's stem retracts upon control air supply failure (valve opens).
Indirect function ensures that actuator's stem extends upon control air supply failure (valve closes).

Dimensions and weights for Foxboro actuators

Type	Actuator							Hand wheel		Weight [kg]	
	A	B	C	G	H	J	T	D _s	E	Actuator	Act. w. HW
	[mm]	[mm]	[mm]	[mm]	[mm]	[mm]	[mm]	[mm]	[mm]		
PB 502	352	82	460	M10x1	40	140	20	250	745	29	38
PB 700	405	65	545	M16x1.5	20	105	16	350	870	40	58
		82	550		40	140	20		875		
PB 1502	550	150	750	M20x1.5	80	160	---	---	---	148	---

Pozn.: Missing data to be given by producer.

Valve specification No. of Foxboro actuators

	PX XXXX	X	XX	X	X	X
Type of actuator	PB 502					
	PB 700					
	PO 1502					
Colour	White	B				
Spring range [bar]	2,0 - 3,5		FS			
	2,0 - 4,8		FY			
	1,8 - 2,7		JC			
	1,5 - 3,8		VI			
	1,5 - 2,7		VC			
Hand wheel	Without wheel				O	
	Heavy wheel ¹⁾				H	
Function	Fail to open					A
	Fail to close					Z
Stroke [mm]	20					A
	40					B
	60					C
	80					D

DN	Actuator type	Function	Stroke [mm]	Spring range [bar]	Setting of spring [bar]	Feeding pressure min. [bar]
15, 25	PB 502 BVCxZB	closing	40	1,5 - 2,7	2,22 - 2,7	5
	PB 502 BFSxAB	opening	40	2 - 4,8	2 - 3,12	5,2
	PB 700 BJCxZA	closing	20	1,5 - 2,7	1,98 - 2,7	4,8
	PB 700 BJCxAA	opening	20	1,8 - 2,7	1,8 - 2,52	4,5
40, 50, 65	PB 700 BVlxZB	closing	40	1,5 - 3,8	2,36 - 3,8	5,3
	PB 700 BVlxAB	opening	40	1,5 - 3,8	1,5 - 2,93	5,3
80, 100, 125	PB 700 BVlxZC	closing	60	1,5 - 3,8	2,26 - 3,8	5,3
	PB 700 BVlxAC	opening	60	1,5 - 3,8	1,5 - 3,03	5,3
150	PO 1502 BFSOZD	closing	80	2 - 3,5	2,3 - 3,5	5
	PO 1502 BFSOAD	opening	80	2 - 3,5	2 - 3,18	5

¹⁾ only for PB 502 a PB 700 actuators

Dimensions for Foxboro actuators

PB 502, PB 700

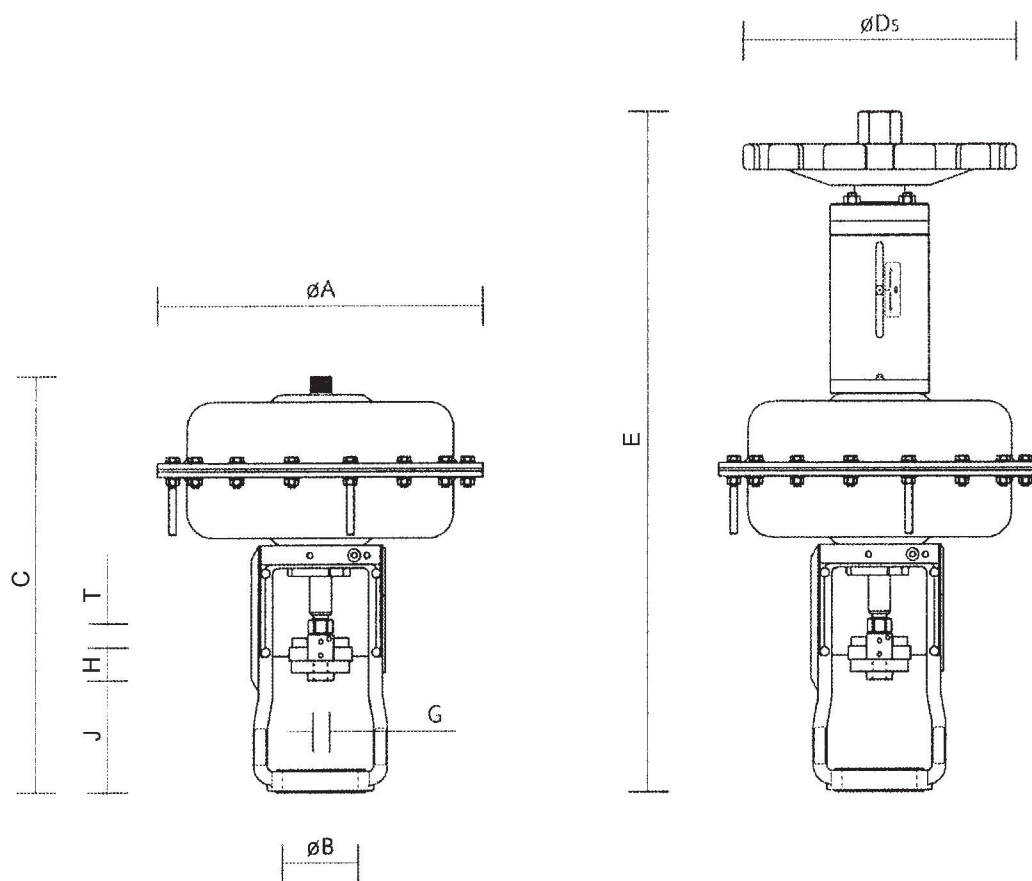

PO 1502

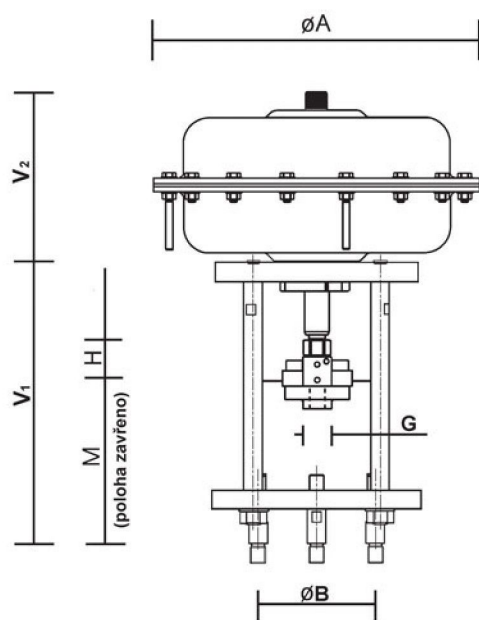

Maximal permissible pressure values [MPa]

Material	PN	Temperature [°C]									
		100	150	200	250	300	350	400	450	500	550
Cast steel 1.0619	16	1.36	1.27	1.14	1.04	0.94	0.88	0.84	---	---	---
	25	2.13	1.98	1.78	1.62	1.47	1.37	1.32	---	---	---
	40	3.41	3.17	2.84	2.60	2.35	2.19	2.11	---	---	---
	63	5.37	4.99	4.48	4.09	3.71	3.45	3.33	---	---	---
	100	8.53	7.92	7.11	6.50	5.89	5.48	5.28	---	---	---
	160	13.6	12.7	11.4	10.4	9.40	8.80	8.40	---	---	---
Alloy steel 1.7357	16	1.63	1.58	1.49	1.43	1.33	1.23	1.15	1.07	0.89	0.35
	25	2.54	2.48	2.33	2.23	2.08	1.93	1.80	1.67	1.39	0.55
	40	4.07	3.96	3.74	3.57	3.33	3.09	2.89	2.67	2.23	0.88
	63	6.41	6.24	5.88	5.63	5.24	4.86	4.55	4.20	3.51	1.39
	100	10.17	9.90	9.34	8.93	8.32	7.71	7.22	6.67	5.57	2.21
	160	16.3	15.8	14.9	14.3	13.3	12.3	11.5	10.7	8.90	3.50

Notes :