

**Injection head (mechanical type)**

---





## Injection head DN 25, 40, 50 PN 25 to 160

### Description

The injection head (further in text only VH) is a device designed to control the temperature of steam. VH is equipped with a mechanical spraying nozzle with changable flow. The nozzle is designed to create tiny drops of cooling water independently on water quantity. Water is sprayed proportionally so it could quickly evaporate. Injected water quantity is controlled by a separate control valve.

VH is supplied in flanged possibly welded connection with connection flange 2 (connection to steam pipeline) of DN 50 (for temperature of 350°C max. only) or DN 80 with 1 to 3 nozzles and dimensions corresponding to the customer's requirements.

### Application

VH serves for precise and economical temperature regulation by a direct installing of cooling water into steam flow. VH is designed especially for industrial applications such as low-pressure steam production in heating, steam circuits in power plants or technological processes.

### Process media

VH is designed to inject cooling water without mechanical impurities. Application of VH for other process media must be considered with regard to the used material that is in contact with medium and it is recommended to consult it with the producer.

### Installation

VH must be installed into pipeline always the way so that the flow of cooled medium will coincide with the arrows indicated on the flange No. 2. As far as the dismantling is considered, it is recommended to leave free space of min. Height that is equal to the distance between flange lower edge and end point of body bent (length "L"). VH can be piped in horizontal, vertical or inclined pipeline in any position.

### Technical data

Series	VH		
Execution	Injection head with 1, 2 or 3 nozzles		
Nominal diameter	Flange 1 ... 25, 40, 50; flange 2 ... 50 and 80		
Nominal pressure	25 to 160		
Opening overpressure	0,2 or 0,4 MPa		
Leakage rate	Acc. to ČSN EN 1349 (5/2001) Class I.		
Operating temperature range	-20 to 350°C		-20 to 550°C
Flange 1 material	DN 25, 40, 50	Cast steel 1.0425	Alloy steel 1.7335
Flange 2 material	DN 50 and 80	Cast steel 1.0425	Alloy steel 1.7335
Pipe material		Cast steel 1.0425	Alloy steel 1.7335
Connection dimensions (flange 1 / weld ends)	Acc. to ČSN EN 1092-1 (2/2003) / ČSN EN 12627 (8/2000) *1)		
Body material	1.4922		

\*1) Dimensions and type of connection (flange / weld) acc. to customers requirements. It shall be specified in the order.

### Kvs values

DN	No. of nozzles		
	1	2	3
25	2.4	---	---
40	2.4	4.8	---
50	---	---	7.2

# Connection dimensions of VH

Flange 1 \*)

DN	PN 25 and 40					PN 63					PN 100					PN 160				
	D <sub>1</sub>	D <sub>2</sub>	n	d	x°	D <sub>1</sub>	D <sub>2</sub>	n	d	x°	D <sub>1</sub>	D <sub>2</sub>	n	d	x°	D <sub>1</sub>	D <sub>2</sub>	n	d	x°
	mm	mm	pcs	mm		mm	mm	pcs	mm		mm	mm	pcs	mm		mm	mm	pcs	mm	
25	115	85	4	14	45	140	100	4	18	45	140	100	4	18	45	140	100	4	18	45
40	150	110	4	18	45	170	125	4	22	45	170	125	4	22	45	170	125	4	22	45
50	165	125	4	18	45	180	135	4	22	45	195	145	4	26	45	195	145	4	26	45

DN	d <sub>1</sub>	d <sub>2</sub>	A	B <sub>min</sub> *)	C <sub>min</sub> *)	F	L <sub>max</sub>
	mm	mm	mm	mm	mm	mm	mm
25	66	76	41	150	160	33	385
40	66	76	41	194	163	33	385
50	66	76	41	280	240	33	385

Flange 2

DN	PN 100			
	D <sub>1</sub>	D <sub>2</sub>	n	d
	mm	mm	pcs	mm
50	195	145	4	26
80	230	180	8	26

The missing data correspond to dimensions of steam pipeline and customers requirements.

\*1) Dimensions and type of connection (flange / weld) acc. to customers requirements. It shall be specified in the order.

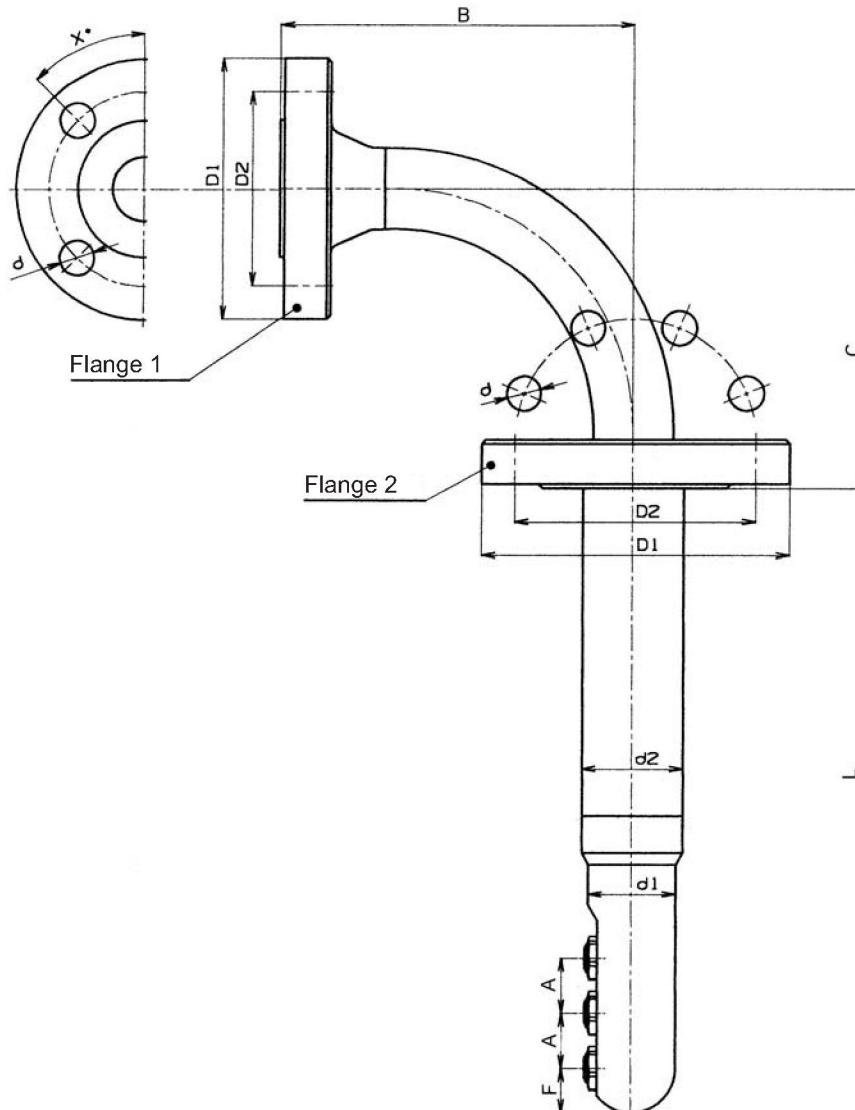

# Complete specification No. for ordering VH

		XX	X	XX	/	XX	-	XXX	X	X	XXX
1. Series	Injection head	VH									
2. No. of nozzles	1		1								
	2		2								
	3		3								
3. DN flange 2	DN 50 (for execution up to 350°C only)			50							
	DN 80			80							
4. DN flange 1	DN 25				25						
	DN 40				40						
	DN 50				50						
5. PN of inlet medium (cooling medium)	PN 25							025			
	PN 40							040			
	PN 63							063			
	PN 100							100			
	PN 160							160			
6. Pipe material	Cast steel 1.0425 (-20 to 350°C)									1	
	Alloy steel 1.7335 (-20 to 550°C)									2	
7. Opening pressure	0,2 MPa										1
	combination of 0,2 and 0,4 MPa										2
	0,4 MPa										3
8. Length L	Acc. to execution										XXX

**Ordering example :** Injection head with 1 nozzle, flange 2 DN 80, flange 1 DN 25, PN 160, body material: cast steel 1.0425, opening pressure 0,4 MPa, length L = 300 mm is marked as follows : **VH1 80/25-160 1 3 300**

## Note

It is necessary to specify nominal pressure PN and nominal size DN of steam pipeline in the order possibly after the agreement with the producer also parameters that do not correspond to the catalogue.

## Max. permissible operating pressures [MPa]

Material	PN	Temperature [ °C ]								Testing pressure at 20°C
		200	250	300	350	400	450	500	550	
Cast steel 1.0425	25	1,78	1,62	1,47	1,37	---	---	---	---	3,80
	40	2,84	2,60	2,35	2,19	---	---	---	---	6,00
	63	4,48	4,09	3,71	3,45	---	---	---	---	9,50
	100	7,11	6,50	5,89	5,48	---	---	---	---	15,0
	160	11,4	10,4	9,40	8,80	---	---	---	---	24,0
Alloy steel 1.7335	25	---	---	2,08	1,93	1,80	1,67	1,39	0,55	5,30
	40	---	---	3,33	3,09	2,89	2,67	2,23	0,88	8,40
	63	---	---	5,24	4,86	4,55	4,20	3,51	1,39	13,0
	100	---	---	8,32	7,71	7,22	6,67	5,57	2,21	21,0
	160	---	---	13,3	12,3	11,5	10,7	8,90	3,50	34,0